

**UTILITY CONTACTS**

THE EXISTING UTILITIES LISTED BELOW AND SHOWN ON THE PLANS REPRESENT THE BEST INFORMATION AVAILABLE AT THE TIME OF PREPARING THESE PANS. THIS INFORMATION DOES NOT RELIEVE THE CONTRACTOR OF THE RESPONSIBILITY TO BE SATISFIED AS TO ITS ACCURACY AND LOCATION OF EXISTING UTILITIES.

CHARTER COMMUNICATIONS  
ATT: MARK KELLY  
1480 S. VALLEY CENTER DRIVE  
BAY CITY, MI 49706

CABLE TV  
PHONE: 989-233-8404  
mark.kelly@charter.com

CITY OF OWOSSO  
ATT: CLAYTON WEHNER, P.E.  
301 W. MAIN STREET  
OWOSSO, MI 48867

ROAD  
989-725-0551  
clayton.wehner@ci.owosso.mi.us

CITY OF OWOSSO  
ATT: RYAN SUCHANEK  
301 W. MAIN STREET  
OWOSSO, MI 48867

SANITARY SEWER & WATER MAIN  
989-725-0550  
ryan.suchanek@ci.owosso.mi.us

CONSUMERS ENERGY  
ATT: TRACY MAHAR  
1801 W. MAIN ST  
OWOSSO, MI 48867

ELECTRIC  
OFFICE: 989-729-3250  
CELL: 517-204-9018  
trmahar@cmsenergy.com

CONSUMERS ENERGY  
ATT: ADAM BERTRAM  
530 W. WILLOW STREET  
P.O. BOX 30162  
LANSING, MI 48909

GAS  
OFFICE: 517-374-2375  
CELL: 517-614-8570  
adam.bertram@cmsenergy.com

DAYSTARR COMMUNICATIONS  
ATT: JARED JACKSON  
307 N. BALL STREET  
OWOSSO, MI 48867

FIBER  
PHONE: 989-720-6004  
FAX: 989-720-6060  
jared.jackson@daystarrfiber.net

FRONTIER COMMUNICATIONS  
ATT: HAROLD ROTH  
1943 W. M-21  
OWOSSO, MI 48847

FIBER  
PHONE: 989-627-9759  
harold.roth@ftr.com

SHIAWASSEE COUNTY HEALTH DEPARTMENT  
ENVIRONMENTAL HEALTH DIVISION  
ATT: STEVE ALWORDEN  
201 N. SHIAWASSEE STREET  
CORUNNA, MI 48817

SOIL EROSION AND SEDIMENTATION CONTROL  
PHONE: 989-743-2289  
FAX: 989-743-2413  
salworden@shiasseechd.net

CALL MISS DIG AT 1-800-482-7171 OR 811 THREE DAYS, EXCLUDING SATURDAY, SUNDAY, AND HOLIDAY, BEFORE STARTING YOUR PROJECT.

**MDOT ROAD STANDARD PLANS**

WHERE THE FOLLOWING ITEMS ARE CALLED FOR ON PLANS, THEY ARE TO BE CONSTRUCTED ACCORDING TO THE MDOT STANDARD PLAN GIVEN BELOW OPPOSITE EACH ITEM UNLESS OTHERWISE INDICATED.

- |  |         |
|--|---------|
| DRAINAGE STRUCTURES  | R-1-G*  |
| COVER B  | R-7-F   |
| MONUMENT BOXES   | R-11-E  |
| COVER K  | R-15-F  |
| COVER Q  | R-18-F  |
| SIDEWALK RAMP AND DETECTABLE WARNING DETAILS   | R-28-J* |
| DRIVEWAY OPENINGS & APPROACHES AND CONCRETE SIDEWALKS  | R-29-I  |
| CONCRETE CURB AND CONCRETE CURB AND GUTTER*  | R-30-G  |
| BUMPER & PARKING RAIL AND MISC. WOOD POSTS   | R-74-D  |
| GRANULAR BLANKET, UNDERDRAINS, AND OUTLET ENDINGS FOR SEWER UNDERDRAINS, AND SEWER BULKHEADS | R-80-E  |
| BEDDING AND FILLING AROUND PIPE CULVERTS   | R-82-D  |
| UTILITY TRENCHES   | R-83-C  |
| SOIL EROSION & SEDIMENT CONTROL MEASURES   | R-96-E  |
| SEEDING AND TREE PLANTING  | R-100-H |

\*SPECIAL DETAILS INCLUDED IN PROPOSAL OR MODIFIED IN GENERAL PLANS

# CITY OF OWOSSO

## 2024 WATER MAIN REPLACEMENT PROJECT

### DWSRF 7497-01

#### SHIAWASSEE COUNTY

SECTIONS 23 & 24, T7N-R2E, CITY OF OWOSSO  
SECTION 18, T7N-R3E, CITY OF OWOSSO  
POP: 15,194 (2010 CENSUS)

SHEET NO.	DESCRIPTION
CS	COVER SHEET
D1	WATER MAIN NOTES AND DETAILS
D2	WATER MAIN STANDARD DETAILS
D3	STREET ITEMS GENERAL NOTES AND DETAILS
D4	SESC STANDARD NOTES AND DETAILS
DW1	DEWEY ST - TRAFFIC CONTROL PLAN
DW2-DW3	DEWEY ST - WATER MAIN PLAN AND PROFILE
DW4	DEWEY ST - SIDEWALK RAMP DETAIL
GR1	GRACE ST - TRAFFIC CONTROL PLAN
GR2-GR3	GRACE ST - WATER MAIN PLAN AND PROFILE
GR4	GRACE ST - SIDEWALK RAMP DETAIL
TR1	TRACY ST - TRAFFIC CONTROL PLAN
TR2-TR3	TRACY ST - WATER MAIN PLAN AND PROFILE
YN1	YOUNG ST - TRAFFIC CONTROL PLAN
YN2	YOUNG ST - REMOVAL PLAN
YN3	YOUNG ST - SANITARY SEWER PLAN AND PROFILE
YN4-YN5	YOUNG ST - WATER MAIN PLAN AND PROFILE



PROJECT LOCATION - DEWEY STREET

PROJECT LOCATION - YOUNG STREET

PROJECT LOCATION - TRACY STREET

PROJECT LOCATION - GRACE STREET

THE MATERIAL AND METHODS FOR WATER MAIN CONSTRUCTION CONFORM TO THE STANDARDS OF THE AMERICAN WATER WORKS ASSOCIATION (AWWA) AND THE MICHIGAN SAFE DRINKING WATER ACT 1976 PA 399, AS AMENDED, AND THE ADMINISTRATIVE RULES.

CONTRACT FOR: 0.90 MILES OF WATER MAIN REPLACEMENT WITH WATER SERVICE LINE REPLACEMENTS AND 275 FEET OF SANITARY SEWER REPLACEMENT.

CITY OF OWOSSO APPROVAL

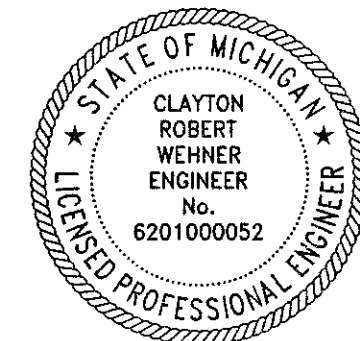

Clayton Wehner  
DIRECTOR OF ENGINEERING CLAYTON WEHNER, PE  
620100052  
REGISTRATION NUMBER  
1/15/24  
DATE



LOCATION MAP  
CITY OF OWOSSO

CITY OF OWOSSO, MICHIGAN  
ENGINEERING DIVISION  
DEPT. OF PUBLIC SERVICE

NO.	DATE	BY	REVISIONS
1	1/15/24	CW	IFB PLANS

APPROVED BY: \_\_\_\_\_  
CHECKED BY: \_\_\_\_\_  
ORIGINAL PLAN

BENCH MARK DATA  
DESCRIPTION  
ELEV.

2024 WATER MAIN REPLACEMENT PROJECT - DWSRF 7497-01  
COVER SHEET  
JANUARY 2024  
PROJECT NO.

FIELD BOOK  
P.G.

CS

**WATER MAIN CONSTRUCTION NOTES**

- ALL WATER MAIN MAIN LINE PROPOSED FOR THIS PROJECT HAS BEEN DESIGNED FOR AND SHALL BECOME A PUBLIC SYSTEM.
- A WATER MAIN CONSTRUCTION PERMIT FROM THE MICHIGAN DEPARTMENT OF ENVIRONMENT, GREAT LAKES, AND ENERGY MUST BE ISSUED PRIOR TO BEGINNING THE CONSTRUCTION OF ANY WATER MAIN IN THIS PROJECT.
- ALL CONSTRUCTION SHALL CONFORM TO THE CITY OF OWOSSO SPECIAL PROVISION FOR WATER MAIN INSTALLATION AND THE STANDARD DETAILS.
- ALL PUBLIC WATER MAIN SHALL BE OWNED AND MAINTAINED BY THE CITY OF OWOSSO UPON COMPLETION OF THE PROJECT.
- ALL PUBLIC WATER MAIN SHALL BE PVC AWWA C900/C909. TRACER WIRE AND BOXES SHALL CONFORM TO THE CITY OF OWOSSO SPECIAL PROVISION FOR WATER MAIN INSTALLATION.
- ALL PIPES, PIPE FITTINGS, PLUMBING FITTINGS, AND FIXTURES THAT ARE USED FOR POTABLE WATER MUST COMPLY WITH THE LEAD FREE REQUIREMENT AND MUST BEAR THE MARK NSF/ANSI STANDARD 61, ANNEX G OR NSF 61-G.
- GATE VALVES SHALL BE EAST JORDAN RESILIENT SEATED GATE VALVES CONFORMING TO AWWA C509. VALVES SHALL BE VERTICAL, NON-RISING STEM AND OPEN CLOCKWISE. SEE CITY OF OWOSSO SPECIAL PROVISION FOR WATER MAIN INSTALLATION AND STANDARD DETAILS.
- FIRE HYDRANTS SHALL CONFORM TO THE SPECIFICATION SHOWN ON THIS SHEET.
- WHERE SANITARY SERVICE LEADS OR OTHER UTILITIES ARE ENCOUNTERED DURING THE CONSTRUCTION OF THE WATER MAIN, THE CONTRACTOR SHALL MAKE ADJUSTMENTS TO EITHER THE WATER MAIN OR EXISTING UTILITY TO PROVIDE CONTINUOUS SERVICE TO PROPERTIES ALONG THE ROUTE OF CONSTRUCTION. ALL WORK INCLUDING THE REBORING OF SANITARY SEWER SERVICE LEADS TO ACCOMMODATE CONSTRUCTION OR ADJUSTING WATER MAIN CONSTRUCTION TO CLEAR EXISTING SERVICES SHALL BE CONSIDERED INCLUSIVE TO CONSTRUCTION OF THE WATER MAIN.
- PRESSURE TAPS TO EXISTING WATER MAINS AND CONNECTIONS TO EXISTING VALVES SHALL BE MADE ONLY UNDER CITY OF OWOSSO OBSERVATION. ALL VALVE OPENING AND CLOSING SHALL BE BY THE CITY OF OWOSSO PERSONNEL. A FULL DIAMETER STAINLESS STEEL TAPPING SLEEVE IS REQUIRED FOR ALL PRESSURE TAPS.
- ALL WATER MAIN SHALL HAVE A MINIMUM COVER OVER THE TOP OF THE PIPE OF 5.5 FEET FROM FINISHED GRADE. THE STANDARD LAYING CONDITIONS FOR WATER MAIN SHALL BE A 30" TRENCH WIDTH OR PIPE DIAMETER PLUS 12". THE PIPE SHALL BE LAID ON A 4" PREPARED SAND CUSHION WITH RECESSES TO ACCOMMODATE PIPE BELLS.
- ALL WATER SERVICE LEADS SHALL HAVE A MINIMUM COVER OVER THE TOP OF THE PIPE OF 5 FEET FROM FINISHED GRADE.
- ALL TRENCH EXCAVATION UNDER OR WITHIN 5' OF EXISTING OR PROPOSED PAVING SHALL BE BACKFILLED WITH CLASS II COMPACTED GRANULAR MATERIALS.
- MINIMUM HORIZONTAL SEPARATION BETWEEN WATER MAIN AND SEWERS SHALL BE 10 FEET.
- CONTRACTOR SHALL RESTRAIN ALL THRUST IN THE SYSTEM BY THE USE OF MEGA-LUG RESTRAINED JOINTS. ALL HYDRANTS, TEES, VERTICAL OR HORIZONTAL BENDS AND FUTURE VALVE CONNECTIONS SHALL BE RESTRAINED. RESTRAINTS SHALL HAVE APPROVAL PRIOR TO BEING INCORPORATED INTO PROJECT CONSTRUCTION.
- WATER MAINS SHALL BE PRESSURE TESTED IN ACCORDANCE WITH AWWA STANDARD C605, AND DISINFECTED IN ACCORDANCE WITH AWWA STANDARD C651. WATER MAIN CHLORINATION SHALL BE OBSERVED AND MONITORED BY CITY OF OWOSSO REPRESENTATIVE.
- WATER SERVICE LEADS SHALL BE TYPE "K" COPPER AND SHALL BE A MINIMUM OF ONE-INCH (1") IN DIAMETER. ALL SERVICE LEADS SHALL BE BORED UNDER ROADWAY. CORPORATIONS SHALL BE BRONZE ALLOY OR BRASS AND COMPLY WITH NSF/ANSI-372 OR NSF/ANSI-61G.
- THE CONTRACTOR SHALL INSTALL TWO INCH CORPORATIONS ON THE WATERLINE FOR PRESSURE TESTING, CHLORINE ADDITION AND FOR BLOW-OFF PURPOSES. THE CORPORATIONS SHALL HAVE COPPER PIPE EXTENDING TO THE GROUND SURFACE. THE CONTRACTOR SHALL REMOVE THE CORPORATION AND COPPER LINE UPON A SATISFACTORY TEST AND INSTALL A PLUG.
- THE CONTRACTOR SHALL ENCASE THE WATER MAIN IN PLASTIC OR CONCRETE PIPE WHERE VERTICAL SEPARATION BETWEEN STORM SEWER AND WATER MAIN OR SANITARY SEWER AND WATER MAIN IS LESS THAN EIGHTEEN (18) INCHES, AS PER MICHIGAN DEPARTMENT OF ENVIRONMENT, GREAT LAKES, AND ENERGY.
- WHERE WATER MAIN CROSSES BENEATH SANITARY OR STORM SEWER, A SOLID LENGTH OF PIPE SHALL BE POSITIONED BENEATH THE CROSSING TO AVOID PIPE JOINTS IN THE VICINITY OF THE CROSSING.

**FREEBORE NOTE:**  
CONTRACTOR SHALL FREEBORE PROPOSED WATER MAIN WHERE NECESSARY TO SAVE/PROTECT TREES OR AVOID EXISTING UTILITIES AND POLES. COST OF FREEBORE SHALL BE INCLUDED IN THE WATER MAIN PAY ITEM. REQUIRED FREEBORE LOCATIONS SHALL BE DETERMINED IN THE FIELD AND ARE NOT SHOWN ON THE PLANS.

**CONSUMERS ENERGY NOTE:**  
ALL UTILITY POLES SHALL BE PROTECTED BY THE CONTRACTOR DURING CONSTRUCTION. IT IS THE CONTRACTOR'S RESPONSIBILITY TO COORDINATE HIS CONSTRUCTION OPERATIONS WITH AFFECTED UTILITIES AND ADEQUATELY SUPPORT THE POLES.

**WATER USAGE NOTE:**  
A SERVICE CHARGE OF \$1,000 WILL BE REQUIRED AT TIME OF PERMIT APPLICATION. THIS FEE INCLUDES THE MINIMUM CHARGE OF \$60 FOR 5,000 BULK GALLONS OF WATER, PLUS ADDITIONAL CHARGES OF \$12 PER 1,000 GALLONS CONSUMED IN EXCESS OF THE MINIMUM QUANTITY. OWOSSO WATER SYSTEM PERSONNEL WILL ATTACH A WATER METER AND RPZ BACKFLOW PREVENTER TO THE HYDRANT FOR CONTRACTOR USE. IF THE WATER METER AND RPZ IS RETURNED IN GOOD OPERATING CONDITION, THE CONTRACTOR WILL RECEIVE A \$450 REFUND, LESS ADDITIONAL WATER CONSUMED IN EXCESS OF MINIMUM QUANTITY.

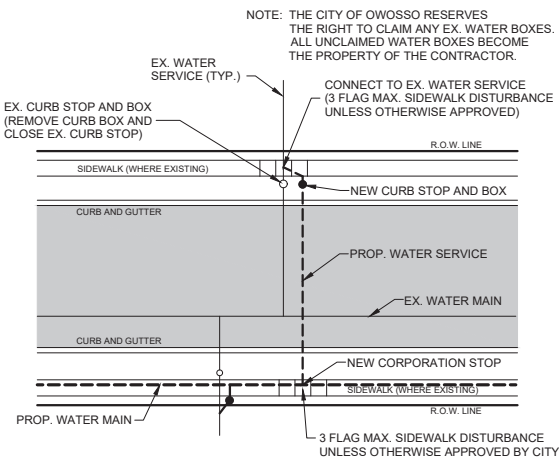

**NEW WATER SERVICE CONNECTION DETAIL**  
NOT TO SCALE

WATER SERVICES ON THE OPPOSITE SIDE OF THE ROAD OF THE NEW WATER MAIN SHALL BE BORED. WATER SERVICES INTO BUILDINGS SHALL BE BORED. CONNECTIONS SHALL BE MADE IN ACCORDANCE WITH THE METER DETAIL ON THE RIGHT.

WATER SERVICES ON THE SAME SIDE OF THE ROAD AS THE NEW WATER MAIN SHALL BE OPEN CUT.

WHERE THE EXISTING CURB STOP BOX IS LOCATED IN PAVEMENT, PAVEMENT REMOVAL AND DRIVE RESTORATION WILL BE PAID SEPARATELY. CONTRACTOR SHALL MINIMIZE PAVEMENT DISTURBANCE AS DIRECTED BY THE ENGINEER.

METER PITS, WHERE VISIBLE AT TIME OF TOPOGRAPHIC SURVEY, ARE SHOWN.

SIDEWALK REMOVAL AND REPLACEMENT FOR WATER SERVICE LINE REPLACEMENT IS NOT SHOWN ON PLAN SHEETS AND SHALL BE AS DIRECTED BY ENGINEER

**MISCELLANEOUS ESTIMATES**

THE FOLLOWING ITEMS OF WORK SHALL BE DONE AS THEY APPLY THROUGHOUT THE PROJECT. THESE ITEMS ARE NOT DETAILED OR INCLUDED ON THE PLAN AND PROFILE SHEETS

Quantity	Unit	Pay Item
1	LSUM	Mobilization, Max \$184,200, Water Main
1	LSUM	Mobilization, Max \$12,400, Sanitary Sewer
400	Syd	Pavt, Rem
460	Syd	Sidewalk, Rem
300	Syd	Aggregate Base, 8 inch, Modified
10	Ea	Dr Structure Cover, Adj, Case 1
100	Ton	HMA, 13A
100	Syd	Driveway, Nonreinf Conc, 6 inch
3105	Sft	Sidewalk, Conc, 4 inch
1035	Sft	Sidewalk Conc, 6 inch
10	Ea	Sanitary Serv Conflict
10	Ea	Abandoned Gas Main Conflict
10	Ea	Sign, Type III, Rem
10	Ea	Sign, Type III, Erect, Salv
160	Ft	Post, Steel, 3 pound
200	Syd	Turf Establishment, Performance
300	Ton	Maintenance Gravel
1	LSUM	Testing and Chlorination of Water Main

**MAINTAINING TRAFFIC QUANTITIES**

Quantity	Unit	Pay Item
19	Ea	Barricade, Type III, High Intensity, Double Sided, Furn & Oper
30	Ea	Pedestrian, Type II Barricade, Temp
5	Ea	Lighted Arrow, Type C, Furn & Oper
1	LSUM	Minor Traffic Devices, Max \$20,000
250	Ea	Plastic Drum, High Intensity, Furn & Oper
997	Sft	Sign, Type B, Temp, Prismatic, Furn & Oper
1	LSUM	Traf Regulator Control



**WaterMaster® Fire Hydrant Specification**

WaterMaster® Fire Hydrant Specifications for City of Owosso hydrants with Storz

- Manufacturers shall provide sufficient documentation to assure that their hydrant will successfully meet the latest revisions of AWWA Standard C502. Fire hydrants shall be rated for 250 psi working pressure and be listed by Underwriters Laboratories Inc. (UL246) and meet the test requirements of Factory Mutual (1510) at this pressure.
- Hydrants shall be of a true compression type, opening against the pressure and closing with the pressure. Composition of the main valve shall be a molded rubber having a durometer hardness of 91 +/- 5. The rubber seat valve shall fit a 5/8" opening and not be less than 1" thick.
- Fire hydrants shall be three-way in design, having Harrington 5" Storz G & X Dome pumper nozzle, and 2 1/2" Nat Std 2 7/8" Base, C Dome hose nozzle. Nozzles shall "thread" counterclockwise into hydrant barrel utilizing "o" ring pressure seals. A suitable nozzle lock shall be in place to prevent inadvertent nozzle removal. Wedging devices and/or ductile iron retainer rings to secure nozzles shall not be allowed.
- The lubrication system shall be sealed from the waterway and any external contaminants by use of "o" ring pressure seals. Anti-friction washers shall be in place above and below the thrust collar of the operating nut to further minimize operating torque. The grease reservoir shall be factory filled with an FDA approved food grade lubricant. Oil shall not be used.
- The operating nut shall be a one piece design, manufactured of ASTM B-584 bronze. It shall be 1 1/8" Pentagon- point to flat in size/shape. The operating nut shall be affixed to the bonnet by means of an ASTM B-584 bronze hold down nut. The hold down nut shall be threaded into the bonnet in such a manner as to prevent accidental disengagement during the opening cycle of the hydrant. A resilient weather seal shall be incorporated with the hold down nut, for the purpose of protecting the operating mechanism from the elements.
- The direction of opening shall be right. An arrow shall be cast on the top of the hydrant to indicate the opening direction.
- The hydrant bonnet shall be attached to the upper barrel by no more than six bolts and nuts. All nuts and bolts below grade shall be 304 stainless steel.
- The hydrant will have 6" Depth of bury, unless otherwise noted.
- Hydrants shall be of the "Traffic Model" design, provided with a safety coupling and flange design that will permit a full 360 degree facing of the nozzles. O-rings shall be the Quad-Ring" type and be installed in a groove on the bottom of the joint so that taping or gluing to the upper standpipe or

extension is not required. The safety coupling shall be a one piece design. Multiple parts and cast iron not allowed.

10. The operating stem shall be a two piece design, not less than 1 1/4" diameter (excluding threaded or machined areas). Threads shall be Acme type with no 60 deg. V threads allowed. Travel stops shall be in the inlet/shoe and are not allowed in the bonnet area. Screws, pins, bolts or fasteners used in conjunction with the stem coupling shall be stainless steel.

11. The inside diameter of the hydrant barrels shall not be less than 7 1/4 inches and the hydrant shall be painted Yellow.

12. Heavy duty drip snuff (top plate) and valve seat shall be high strength manganese bronze. Valve seat shall be installed in a bronze seat ring. Drain shall be tapped and plugged, bronze lined and 3/8 inch diameter minimum. They shall operate without the use of springs, toggles, tubes, levers or other intricate synchronizing mechanisms. Lower valve plate shall be a one piece ductile iron casting and not require a separate cap nut. Drains shall be open and flushed during the first 4 turns of opening the hydrant before positively closing while operating the hydrant.

13. The shoe connection shall be Mechanical Joint or as specified. The inlet/shoe shall be fusion bonded epoxy coated per ANSI/AWWA C550 and with an NSF61 approved coating having ample blocking pads for sturdy setting. Six stainless steel bolts and nuts are required to fasten the shoe to the lower barrel. The shoe/inlet shall be directly connected to the standpipe flange. Designs using a sandwich piece in between the standpipe and shoe/inlet shall not be allowed.

14. External parts- the top bonnet, upper standpipe, lower standpipe and shoe shall be ductile iron to ensure strength throughout the exterior of the hydrant. Gray Iron hydrant body parts will not be allowed.

Municipality reserves the right to accept only those materials which are in full compliance with these specifications and deemed most advantageous to its interests.

Upon request, supplier shall furnish flow data indicating friction loss in psi at a flow of 1,000 gpm from the pumper nozzle. Such friction loss shall not exceed 2.5 psi. Also, the municipality may request the manufacturing "point of origin" for any/or all hydrant parts. All cast components shall be made in the USA.

Failure to comply with any of these above requirements is sufficient cause for rejection of proposed hydrants.

Hydrant shall be EJ WaterMaster® 5BR250.  
5726D 6" O' DOB  
53726D 5" O' DOB  
54727D 5.6" DOB

ejco.com 800 626 4653

1

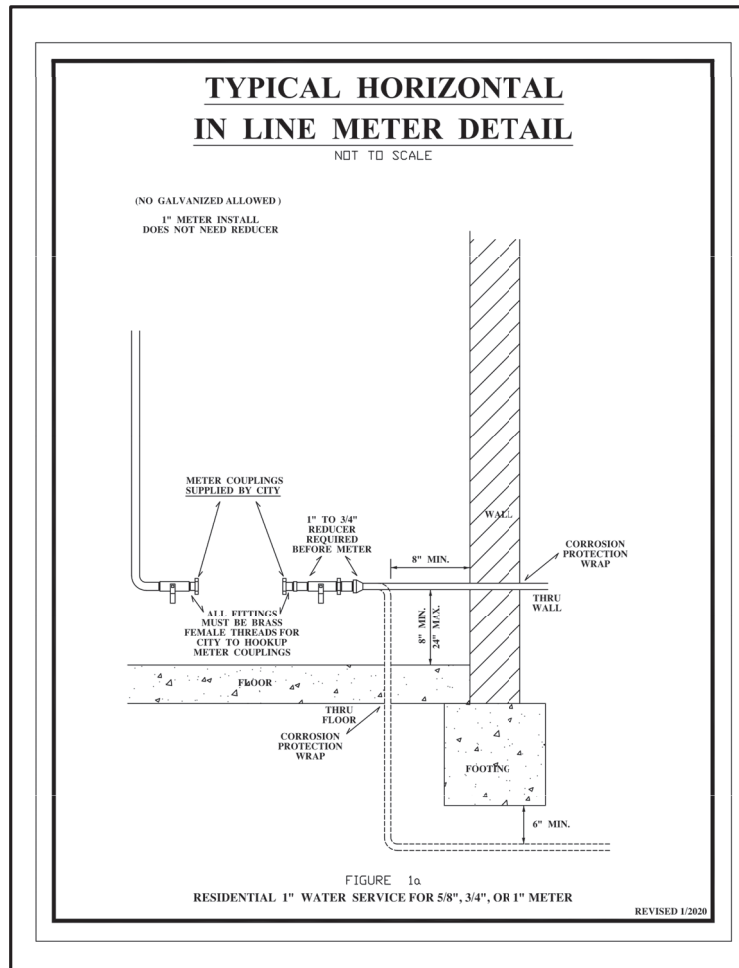

**FIGURE 1a**  
RESIDENTIAL 1" WATER SERVICE FOR 5/8", 3/4", OR 1" METER  
REVISED 1/2020

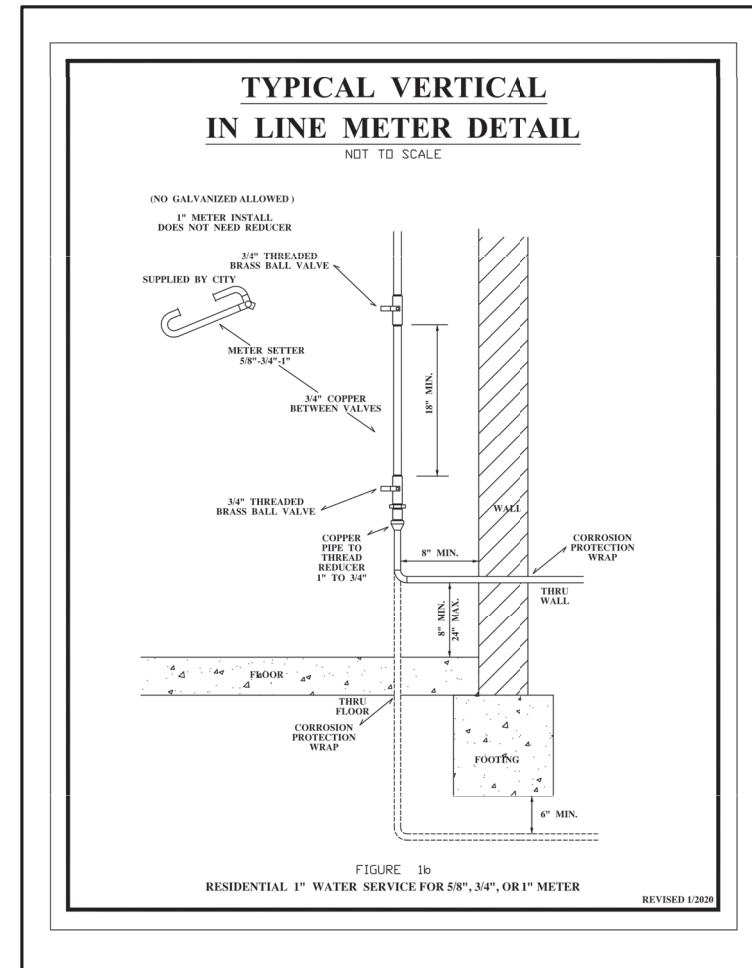

**FIGURE 1b**  
RESIDENTIAL 1" WATER SERVICE FOR 5/8", 3/4", OR 1" METER  
REVISED 1/2020

NO.	REVISIONS	DATE	BY
1	IFB PLANS	1/15/24	CW

BENCH MARK DATA	DESCRIPTION	ELEV.

CHECKED BY: APPROVED BY:

FIELD BOOK P.G.





**GENERAL NOTES**

**UNDERGROUND UTILITIES/MISS DIG**

FOR PROTECTION OF UNDERGROUND UTILITIES AND IN CONFORMANCE WITH PUBLIC ACT 174, 2013, THE CONTRACTOR SHALL DIAL 1-800-482-7171 FOR A MINIMUM OF THREE FULL WORKING DAYS, EXCLUDING SATURDAYS, SUNDAYS, AND HOLIDAYS, PRIOR TO BEGINNING EACH EXCAVATION IN AREAS WHERE PUBLIC UTILITIES HAVE NOT BEEN PREVIOUSLY LOCATED. MEMBER WILL THUS BE ROUTINELY NOTIFIED. THIS DOES NOT RELIEVE THE CONTRACTOR OF THE RESPONSIBILITY OF NOTIFYING UTILITY OWNERS WHO MAY NOT BE A PART OF THE "MISS DIG" ALERT SYSTEM.

THE EXISTING UTILITIES ON THESE DRAWINGS HAVE BEEN SHOWN ACCORDING TO THE BEST AVAILABLE INFORMATION. CONTRACTOR SHALL FIELD LOCATE ALL UTILITIES PRIOR TO BEGINNING CONSTRUCTION AND SHALL NOTIFY THE ENGINEER AS TO WHERE POSSIBLE CONFLICT EXIST.

**EXISTING WATER MAINS AND SEWERS**

THE CONTRACTOR SHALL BE RESPONSIBLE FOR DAMAGE TO PROPERLY IDENTIFIED EXISTING WATER MAINS AND / OR EXISTING SEWERS DURING THE CONSTRUCTION OF THE PROJECT.

**ADJUSTING OF MONUMENT BOXES**

ALL GOVERNMENT CORNERS ON THIS PROJECT SHALL BE PRESERVED, WHETHER SHOWN OR NOT. IT MAY BE NECESSARY TO PLACE OR ADJUST MONUMENT BOXES AS REQUIRED.

**PAVEMENT MARKINGS AND SIGNS**

ALL PERMANENT PAVEMENT MARKINGS, SHAPES, AND DIMENSIONS SHALL CONFORM WITH MDOT PAVEMENT MARKING TYPICALS PAVE - 900 SERIES.

**SOIL EROSION MEASURES**

APPROPRIATE SOIL EROSION AND SEDIMENTATION CONTROL MEASURES SHALL BE IN PLACE PRIOR TO EARTH DISTURBING ACTIVITIES. PLACE LAWN RESTORATION ITEMS AS SOON AS POSSIBLE ON POTENTIAL ERODIBLE SLOPES AS DIRECTED BY THE ENGINEER. CRITICAL DITCH GRADES SHALL BE PROTECTED WITH EITHER SOD OR SEED / MULCH BLANKET AS DIRECTED BY THE ENGINEER.

**SOIL EROSION AND SEDIMENTATION CONTROL MEASURES**

IT IS THE RESPONSIBILITY OF THE CONTRACTOR TO ENSURE THAT SOIL EROSION AND SEDIMENTATION CONTROL MEASURES ARE IN PLACE AND MAINTAINED UNTIL THE CONTRACT HAS BEEN COMPLETED AND ACCEPTED. MEASURES SHALL ONLY BE PAID FOR ONCE.

**RUBBISH DISPOSAL**

SEE MAINTAINING TRAFFIC SPECIAL PROVISIONS.

**MAIL DELIVERY**

SEE MAINTAINING TRAFFIC SPECIAL PROVISIONS.

**STORM SEWER REMOVAL**

REMOVAL OF SEWER WITH DIAMETER LESS THAN 12 INCHES, WITHIN THE EXCAVATION LIMITS OF NEW SEWER, IS INCLUDED IN THE UNIT PRICE FOR NEW SEWER AND WILL NOT BE PAID FOR SEPARATELY.

**SEWER STRUCTURES**

ALL ORIFICES TO RECEIVE SEWER PIPE SHALL BE FITTED WITH KOR-N-SEAL FLEXIBLE CONNECTOR (S) , OR APPROVED EQUAL CONNECTOR. THE FLEXIBLE CONNECTOR WILL NOT BE PAID FOR SEPARATELY, BUT IS CONSIDERED AS PART OF THE DRAINING STRUCTURE PAY ITEM.

**SEWER CONNECTIONS**

PROPOSED SEWERS SHALL BE CONNECTED TO EXISTING SEWERS WITH A FERNCO COUPLER, OR APPROVED EQUAL, AS DIRECTED BY THE ENGINEER. CONNECTION SHALL BE ACCOMPLISHED WITH COUPLER OF SIMILAR SIZE IN ACCORDANCE WITH MANUFACTURER RECOMMENDATIONS. PAYMENT FOR ALL MATERIALS AND LABOR NECESSARY TO ACCOMPLISH THIS WORK WILL NOT BE PAID FOR SEPARATELY, BUT WILL BE CONSIDERED AS PART OF OTHER WORK ITEMS.

**STREET APPROACHES**

STREET APPROACHES SHALL BE PAID FOR AS PART OF THE MAINLINE PAVING PAY ITEMS.

**STRUCTURE ADJUSTMENTS**

ADJUSTMENTS TO STORM AND SANITARY STRUCTURES LOCATED WITHIN THE PAVEMENT OR CURB AND GUTTER SHALL BE PAID FOR AS: Dr Structure Cover, Adj, Case 1.

**CURB AND GUTTER**

ALL NEW SECTIONS OF CURB AND GUTTER SHALL BE TIED TO EXISTING CURB AND GUTTER ON BOTH ENDS USING EPOXY COATED #4 BARS.

**SIDEWALK RAMPS AND SIDEWALKS**

SIDEWALK RAMPS SHALL BE COMPLETED IN ACCORDANCE WITH THE MDOT STANDARD SPECIFICATIONS FOR CONSTRUCTION AND MDOT STANDARD PLAN R-28 SERIES, EXCEPT AS MODIFIED HEREIN. THE PORTION OF RAMP FROM THE CURB AND GUTTER TO THE LANDING SHALL BE 7-INCHES THICK AS IDENTIFIED ON THE SIDEWALK RAMP THICKNESS DETAIL. THE LANDING SHALL BE 4-INCHES THICK. THE PAY ITEMS FOR Curb Ramp, Conc, 7 inch AND Sidewalk, Conc, 7 inch SHALL INCLUDE ALL EXCAVATION AND EMBANKMENT NECESSARY TO CONSTRUCT EACH ITEM AND ALL WORK NECESSARY TO SAW AND TRIM EDGES OF EXISTING CONCRETE. EXCAVATION AND EMBANKMENT WILL NOT BE PAID FOR SEPARATELY.

DETECTIBLE WARNING SURFACES SHALL BE EAST JORDAN DURALAST TM AND BLACK ASPHALT DIPPED, INSTALLED ONTO FRESH CONCRETE, AND IN ACCORDANCE WITH MDOT STANDARD R-28 SERIES. THE WARNING SURFACES SHALL BE 2.5 FEET IN LENGTH SUCH THAT TWO PLATES ARE USED FOR EACH 5 FOOT WIDE RAMP.

SIDEWALKS LOCATED WITHIN RESIDENTIAL DRIVEWAYS SHALL BE 6-INCHES THICK AND WILL BE PAID FOR AS Sidewalk, Conc, 6 inch.

SIDEWALKS LOCATED WITHIN COMMERCIAL DRIVEWAYS SHALL BE 7-INCHES THICK AND WILL BE PAID FOR AS Sidewalk, Conc, 7 inch.

**LAWN SPRINKLERS / LANDSCAPING**

OWNERS OF EXISTING LAWN SPRINKLER SYSTEMS AND / OR LANDSCAPING SHALL BE NOTIFIED ( IN WRITING WITH A COPY SENT TO THE ENGINEER) BY THE CONTRACTOR TWO WEEKS IN ADVANCE OF ANY WORK THAT WILL BE DONE THAT WILL AFFECT THOSE SYSTEMS AND / OR LANDSCAPING. IF THE PROPERTY OWNER FAILS TO RELOCATE THE LAWN SPRINKLER SYSTEM PRIOR TO THE CONTRACTOR BEGINNING WORK, AND IF THE CONTRACTOR CUTS THE SYSTEM DURING CONSTRUCTION, THE CONTRACTOR SHALL CAP THE SYSTEM PIPE AND WITNESS THE LOCATION OF THE CAP WITH A WOODEN STAKE FOR THE PROPERTY OWNERS USE. THE CONTRACTOR SHALL PLACE THE SALVAGED SPRINKLER HEADS ON THE BACK OF THE RIGHT OF WAY. IF THE PROPERTY OWNER FAILS TO RELOCATE THE LANDSCAPING PRIOR TO THE CONTRACTOR BEGINNING WORK, THE CONTRACTOR SHALL CAREFULLY SALVAGE THE LANDSCAPING ITEMS AND STOCKPILE THEM ON THE BACK OF THE RIGHT OF WAY OR AT A LOCATION DESIGNATED BY THE ENGINEER FOR THE PROPERTY OWNER. ANY OTHER MODIFICATION TO THE SPRINKLER SYSTEM AND / OR LANDSCAPING IS THE RESPONSIBILITY OF THE OWNER AND IS NOT PART OF THIS CONTRACT. THIS WORK WILL NOT BE PAID FOR SEPARATELY.

**PROPERTY OWNERS**

PROPERTY OWNERS' NAMES, WHERE SHOWN, ARE FOR INFORMATION ONLY, AND THEIR ACCURACY IS NOT GUARANTEED.

**MAINTAINING TRAFFIC**

REFER TO THE CONTRACT SPECIAL PROVISION FOR WORK RESTRICTIONS RELATIVE TO MAINTAINING TRAFFIC.

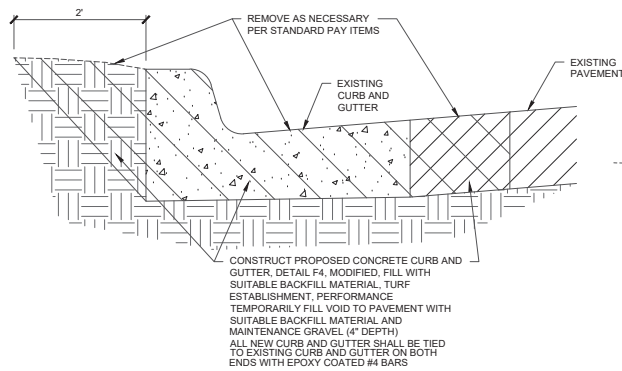

**TYPICAL SELECT CURB AND GUTTER REPAIR DETAIL**  
NOT TO SCALE

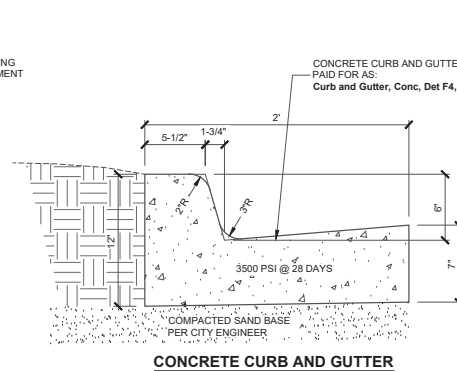

**CONCRETE CURB AND GUTTER MDOT F4 - MODIFIED DETAIL**  
NOT TO SCALE

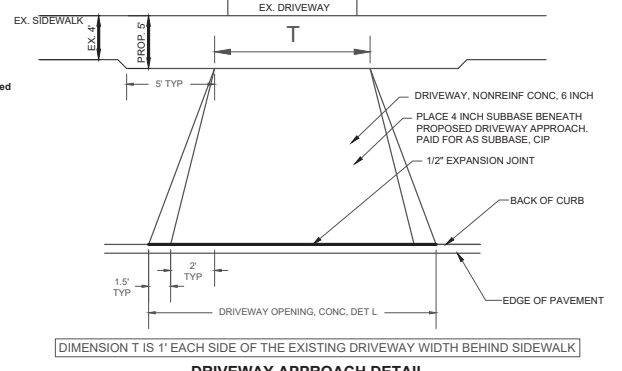

**DRIVEWAY APPROACH DETAIL**  
NOT TO SCALE

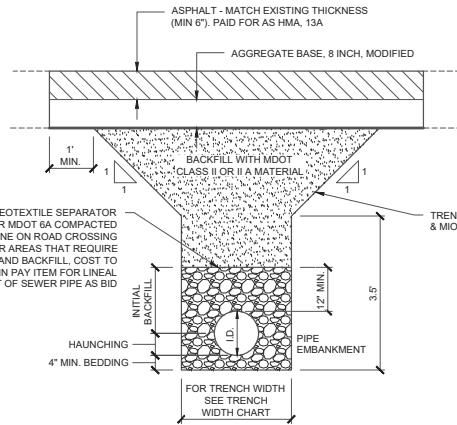

**TRENCH DETAIL B, MODIFIED DETAIL**  
NOT TO SCALE

TRENCH WIDTH CHART		
PIPE SIZE	MINIMUM	MAXIMUM
6", 8" & 10"	24"	30"
12" & 15"	30"	36"
18"	34"	40"
21"	38"	42"
24"	42"	46"
27"	45"	49"
30"	49"	53"
36"	56"	60"
LARGER THAN 36"	I.D. +20"	I.D. +24"

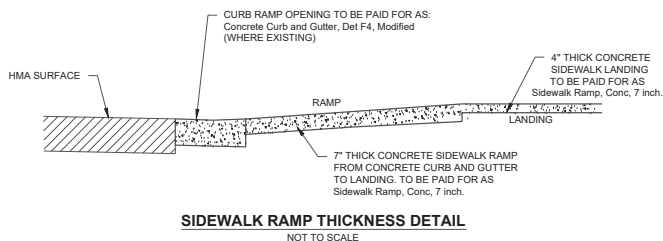

**SIDEWALK RAMP THICKNESS DETAIL**  
NOT TO SCALE

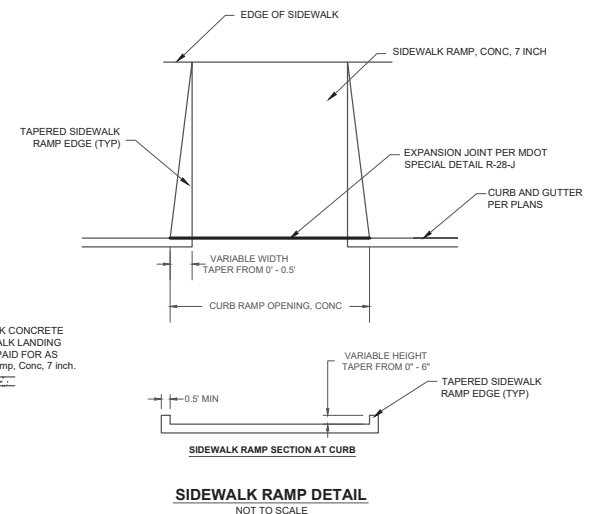

**SIDEWALK RAMP DETAIL**  
NOT TO SCALE

**EXISTING FEATURES LEGEND**

SYMBOL	DESCRIPTION	SYMBOL	DESCRIPTION	SYMBOL	DESCRIPTION
	TREE (DECIDUOUS)		CABLE BOX		SURVEY CONTROL POINT
	BUSH		TELEPHONE RISER		BENCHMARK
	TREE (CONIFEROUS)		TELEPHONE MANHOLE		SECTION CORNER
	DEAD TREE		TELEPHONE HANDHOLE		BOUNDARY LINE
	STUMP		ELECTRICAL RISER		PROPERTY LINE
	MANHOLE		ELECTRICAL MANHOLE		WATERMAIN
	SANITARY CLEANOUT		ELECTRICAL HANDHOLE		SANITARY SEWER
	RD. CATCH BASIN		POWER POLE		STORM SEWER
	SQ. CATCH BASIN		LIGHT POLE		
	FIRE HYDRANT		GUY POLE		CABLE T.V.
	WATER VALVE		GUY ANCHOR		TELEPHONE
	CURB STOP & BOX		PED CROSSING SIGNAL		ELECTRIC
	WELL		YARD LIGHT		GAS
	WATER MANHOLE		SIGN		OVERHEAD LINES
	WATER METER		MAILBOX		GUARDRAIL
	SOIL BORING		GUARD POST		FENCE
	MONITORING WELL		FOUND CONC. MONUMENT		WOODLINE
			FOUND IRON ROD		
			SET IRON ROD		

NOTE: ALL ITEMS LISTED ON THE LEGEND MAY NOT BE PRESENT ON DRAWING.

NO.	DATE	BY	DESCRIPTION	REVISIONS	CHECKED BY	APPROVED BY
1	1/15/24	CW				

2024 WATER MAIN REPLACEMENT PROJECT - DWSRF 7497-01

STREET ITEMS GENERAL NOTES & DETAILS

JANUARY, 2024 PROJECT NO.

D3

CITY OF OWOSO, MICHIGAN  
ENGINEERING DIVISION  
DEPT. OF PUBLIC SERVICE

FIELD BOOK P.G.



MICHIGAN DEPARTMENT OF MANAGEMENT AND BUDGET  
S-E-S-C KEYING SYSTEM

KEY	BEST MANAGEMENT PRACTICES	SYMBOL	WHERE USED
<b>EROSION CONTROLS</b>			
E1	SELECTIVE GRADING AND SHAPING		To reduce steep slopes and erosive velocities.
E2	GRUBBING OMITTED		For use on steep slopes to prevent rilling, gullying, and reduce sheet flow velocity or where clear vision corridors are necessary.
E3	SLOPE ROUGHENING AND SCARIFICATION		Where created grades cause increased erosive velocities. Promotes infiltration and reduces runoff velocity.
E4	TERRACES		On relatively long slopes up to 8% grades with fairly stable soils.
E5	DUST CONTROL		For use on construction sites, unpaved roads, etc. to reduce dust and sedimentation from wind and construction activities.
E6	MULCH		For use in areas subject to erosive surface flows or severe wind or on newly seeded areas.
E7	TEMPORARY SEEDING		Stabilization method utilized on construction sites where earth change has been initiated but not completed within a 2 week period.
E8	PERMANENT SEEDING		Stabilization method utilized on sites where earth change has been completed (final grading attained).
E9	MULCH BLANKETS		On exposed slopes, newly seeded areas, new ditch bottoms, or areas subject to erosion.
E10	SODDING		On areas and slopes where immediate stabilization is required.
E11	VEGETATED CHANNELS		For use in created stormwater channels. Vegetation is used to slow water velocity and reduce erosion within the channel.
E12	RIPRAP		Use along shorelines, waterways, or where concentrated flows occur. Slows velocity, reduces sediment load, and reduces erosion.
E13	GABION WALLS		On newly created or denuded stream banks to reduce velocity until permanent stabilization is achieved or on existing banks to retard erosive velocities.
E14	ENERGY DISSIPATOR		Where the energy transmitted from a concentrated flow of surface runoff is sufficient to erode receiving area or watercourse.
E15	TEMPORARY SLOPE DRAIN		Where surface runoff temporarily accumulates or sheet flows over the top of a slope and must be conveyed down a slope in order to prevent erosion.
E16	SLOPE DRAIN		Where concentrated flow of surface runoff must be permanently conveyed down a slope in order to prevent erosion.

B = BIOENGINEERING

MICHIGAN DEPARTMENT OF MANAGEMENT AND BUDGET  
S-E-S-C KEYING SYSTEM

KEY	BEST MANAGEMENT PRACTICES	SYMBOL	WHERE USED
E17	CELLULAR CONFINEMENT SYSTEMS		Used on steep slopes and high velocity channels.
E18	PLASTIC SHEETS		Used on exposed slopes, seeded areas, new ditch bottoms, and areas subject to surface runoff and erosion. Used as a liner in temporary channels and to stabilize stockpiles.
E19	TEMPORARY DRAINAGEWAY/STREAM CROSSING		Use on construction sites where stream/drainageway crossings are required.
E20	TEMPORARY BYPASS CHANNEL		Use within existing stream corridors when existing flow cannot be interrupted, and at culvert and bridge repair sites.
E21	LIVE STAKING		In areas requiring protection of slopes against surface erosion and shallow mass wasting.
<b>EROSION / SEDIMENT CONTROLS</b>			
ES31	CHECK DAM		Used to reduce surface flow velocities within constructed and existing flow corridors.
ES32	STONE FILTER BERM		Use primarily in areas where sheet or rill flow occurs and to accommodate dewatering flow.
ES33	FILTER ROLLS		In areas requiring immediate protection of slopes against surface erosion and gully formation and for perimeter sediment control.
ES34	SAND FENCE		For use in areas susceptible to wind erosion, especially where the ground has not yet been stabilized by other means.
ES35	DEWATERING		Use where construction activities are limited by the presence of water and dry work is required.
ES36	DIVERSION DIKE/BERM		Within existing flow corridors to address or prevent erosion and sedimentation, or on disturbed or unstable slopes subject to erosive surface water velocities.
ES37	DIVERSION DITCH		In conjunction with a diversion dike, or where diversion of upslope runoff is necessary to prevent damage to unstabilized or disturbed construction areas.
ES38	COFFERDAM/SHEET PILING		Constructed along or within water corridor or waterbody to provide dry construction area.
ES39	STREAMBANK BIOSTABILIZATION		For use along banks where stream and riparian zones may have difficulty recovering from the long-term effects of erosion.
ES40	POLYMERS		To minimize soil erosion and reduce sedimentation in water bodies by increasing soil particle size.
ES41	WATTLES		In areas requiring protection of slopes against surface erosion and gully formation.

B = BIOENGINEERING

MICHIGAN DEPARTMENT OF MANAGEMENT AND BUDGET  
S-E-S-C KEYING SYSTEM

KEY	BEST MANAGEMENT PRACTICES	SYMBOL	WHERE USED
<b>SEDIMENT CONTROLS</b>			
S51	SILT FENCE		Use adjacent to critical areas, to prevent sediment laden sheet flow from entering these areas.
S52	CATCH BASIN SEDIMENT GUARD		Use in or at stormwater inlets, especially at construction sites.
S53	STABILIZED CONSTRUCTION ACCESS		Used at every point where construction traffic enters or leaves a construction site.
S54	TIRE WASH		For use on construction sites where vehicular traffic requires sediment removed from its tires in highly erosive areas.
S55	SEDIMENT BASIN		At the outlet of disturbed areas and at the location of a permanent detention basin.
S56	SEDIMENT TRAP		In small drainage areas, along construction site perimeters, and above check dams or drain inlets.
S57	VEGETATED BUFFER/FILTER STRIP		Use along shorelines, waterways, or other sensitive areas. Slows velocity, reduces sediment load, and reduces erosion in areas of sheet flow.
S58	INLET PROTECTION FABRIC DROP		Use at stormwater inlets, especially at construction sites.
S59	INLET PROTECTION FABRIC FENCE		Use at stormwater inlets, especially at construction sites.
S60	INLET PROTECTION STONE		Use around urban stormwater inlets.
S61	TURBIDITY CURTAIN		Use during construction adjacent to a water source, to contain sediment within the work area when other BMP's cannot be used.

B = BIOENGINEERING

SOIL EROSION/SEDIMENTATION CONTROL OPERATION TIME SCHEDULE												
CONSTRUCTION SEQUENCE	JAN	FEB	MAR	APR	MAY	JUN	JUL	AUG	SEP	OCT	NOV	DEC
STRIP AND STOCKPILE TOPSOIL												
ROUGH GRADE/ SEDIMENT CONTROL												
TEMP CONTROL MEASURES												
STORM FACILITIES								N/A				
TEMP CONSTRUCTION ROADS								N/A				
FOUNDATION/ BLDG. CONSTRUCTION								N/A				
SITE CONSTRUCTION												
PERM CONTROL MEASURES												
FINISH GRADING												
LANDSCAPING								N/A				

CONSTRUCTION SEQUENCE

1. INSTALLATION OF TEMPORARY EROSION CONTROL MEASURES.
2. TRENCH EXCAVATION, WATER MAIN INSTALLATION, AND BACKFILL.
3. PERMANENT MEASURES, FINAL GRADING, SEEDING AND MULCHING.

NO.	DATE	BY	REVISIONS
1	1/15/24	CW	IFB PLANS

BENCH MARK DATA	DESCRIPTION
ELEV.	

# DEWEY STREET CITY OF OWOSSO 2024 WATER MAIN REPLACEMENT PROJECT

SHEET NO.	DESCRIPTION
DW1	DEWEY ST - COVER SHEET & TRAFFIC CONTROL PLAN
DW2-DW3	DEWEY ST - WATER MAIN PLAN AND PROFILE
DW4	DEWEY ST - SIDEWALK RAMP DETAIL

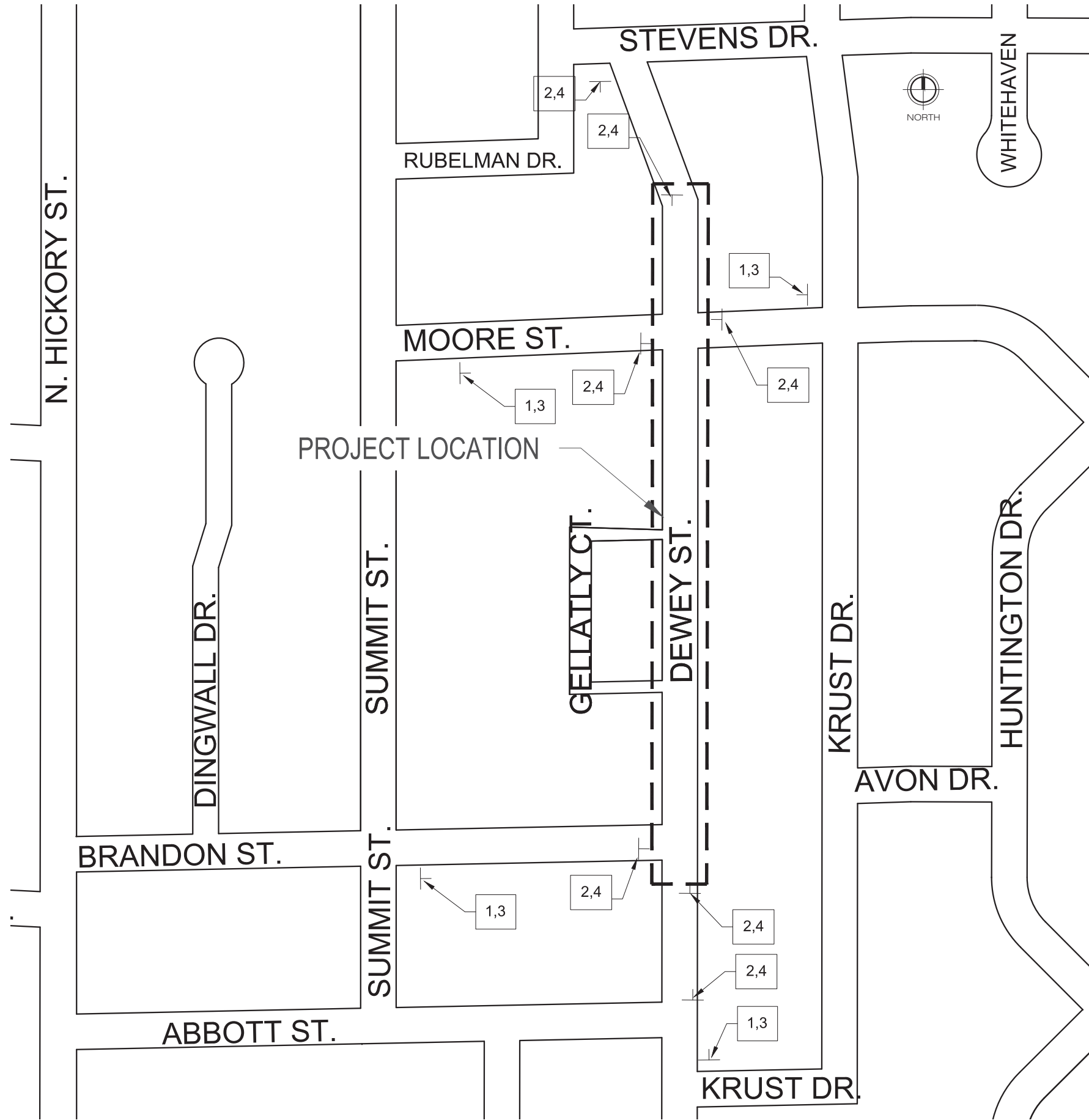

SIGNING REQUIREMENTS					
NO.	SIGN	SIGN DESIGNATION	SIZE	NO. REQ.	TOTAL AREA (SFT)
1		W20-1	48 x 48	4	64
2		R11-3A	60 x 30	7	88
3		M4-8 MOD	30 X 8	4	7
4		TYPE III BARRICADE		7	

### MAINTAINING TRAFFIC LEGEND



CITY OF OWOSSO, MICHIGAN  
ENGINEERING DIVISION  
DEPT. OF PUBLIC SERVICE

NO.	DATE	BY	DESCRIPTION
1	1/15/24	CW	IFB PLANS
			REVISIONS
			CHECKED BY
			APPROVED BY

2024 WATER MAIN REPLACEMENT PROJECT - DWSRF 7497-01  
 DEWEY STREET  
 COVER SHEET & TRAFFIC CONTROL PLAN

JANUARY, 2024  
 PROJECT NO.

FIELD BOOK  
 P.G.

DW1

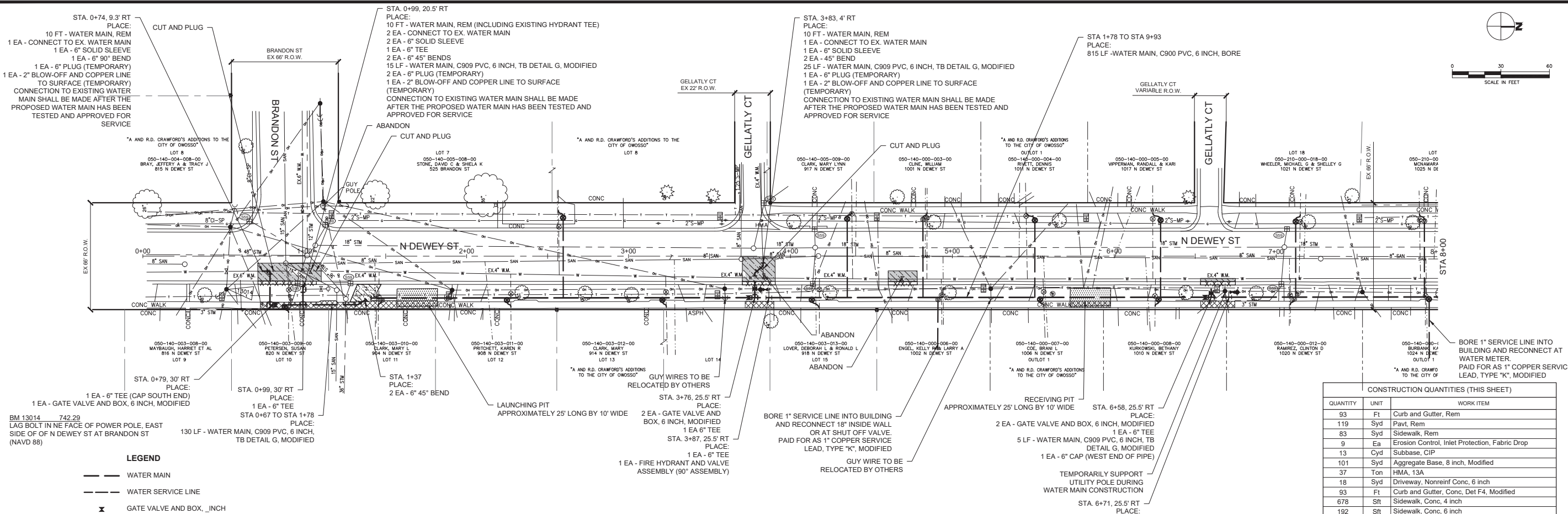
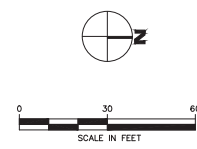

**DEWEY STREET**  
WATER MAIN PLAN

CONSTRUCTION QUANTITIES (THIS SHEET)		
QUANTITY	UNIT	WORK ITEM
93	Ft	Curb and Gutter, Rem
119	Syd	Pavt, Rem
83	Syd	Sidewalk, Rem
9	Ea	Erosion Control, Inlet Protection, Fabric Drop
13	Cyd	Subbase, CiP
101	Syd	Aggregate Base, 8 inch, Modified
37	Ton	HMA, 13A
18	Syd	Driveway, Nonrein Conc, 6 inch
93	Ft	Curb and Gutter, Conc, Det F4, Modified
678	Sft	Sidewalk, Conc, 4 inch
192	Sft	Sidewalk, Conc, 6 inch
400	Syd	Turf Establishment, Performance
4	Ea	Connect to Existing Water Main
30	Ft	Water Main, Rem
3	Ea	Existing Valve with Valve Box Abandonment
160	Ft	Water Main, C909 PVC, 6 inch, TB Detail G, Modified
622	Ft	Water Main, C900 PVC, 6 inch, Bore
2	Ea	Water Main, 4 inch, Cut and Plug, Modified
1	Ea	Water Main, 6 inch, Cut and Plug, Modified
5	Ea	Gate Valve and Box, 6 inch, Modified
2	Ea	Fire Hydrant and Valve Assembly
585	Ft	1" Copper Service Lead, Type "K", Modified
17	Ea	Curb Box, Stop, 1 inch Corporation Stop and Connection, Modified
5	Ea	Supply & Install Meter Pit, Complete
5	Ea	Water Meter Pit, Rem

- LEGEND**
- WATER MAIN
  - WATER SERVICE LINE
  - ✕ GATE VALVE AND BOX, \_INCH
  - REDUCER
  - ⊕ HYDRANT / VALVE
  - ⊙ CURB STOP
  - ⊖ METER PIT
  - ▭ Curb and Gutter, Rem
  - ▭ Sewer, Rem
  - ▭ Pavt, Rem
  - ▭ Sidewalk, Rem and Sidewalk, Conc, \_\_\_ inch or Curb Ramp, Conc, \_\_\_ inch (Proposed sidewalk shall be 5' wide)
  - ▭ Curb and Gutter, Conc, Det F4, Modified
  - ▭ Sewer, SDR-26, \_\_\_ inch, Tr Det B, Modified
  - ▭ Aggregate Base, 8 inch, Modified and HMA, 13
  - ▭ Driveway, Nonrein Conc, \_\_\_ inch
  - ▭ Approach, CI II, LM
  - ⊖ Bore Pit
  - ⊖ STANDARD SOIL EROSION KEY

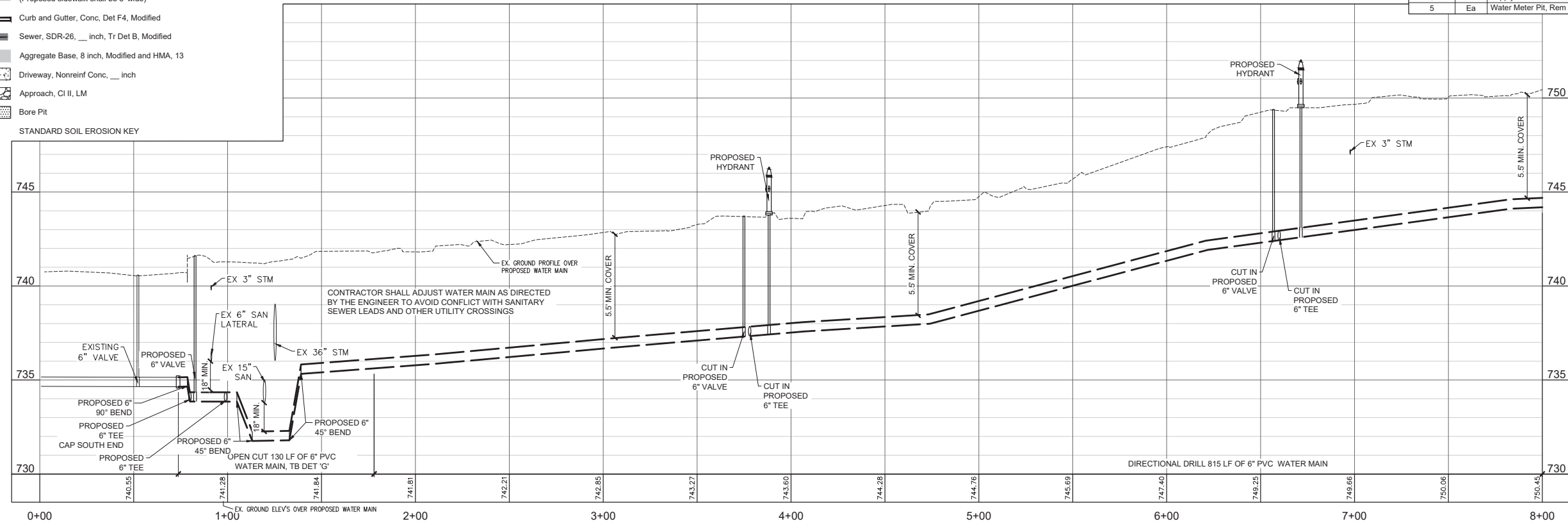

NO.	DATE	BY	DESCRIPTION
1	1/15/24	CW	IFB PLANS

NO.	DATE	BY	DESCRIPTION
			REVISIONS

  

NO.	DATE	BY	DESCRIPTION
			CHECKED BY
			APPROVED BY

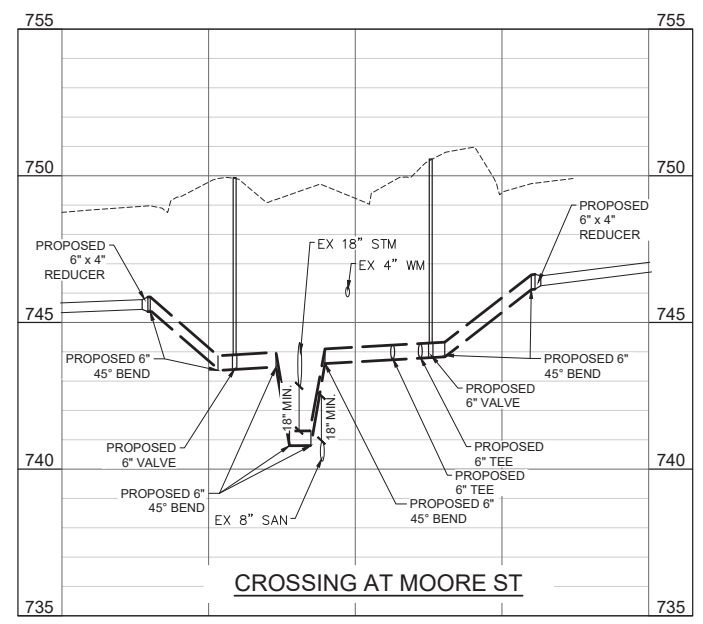
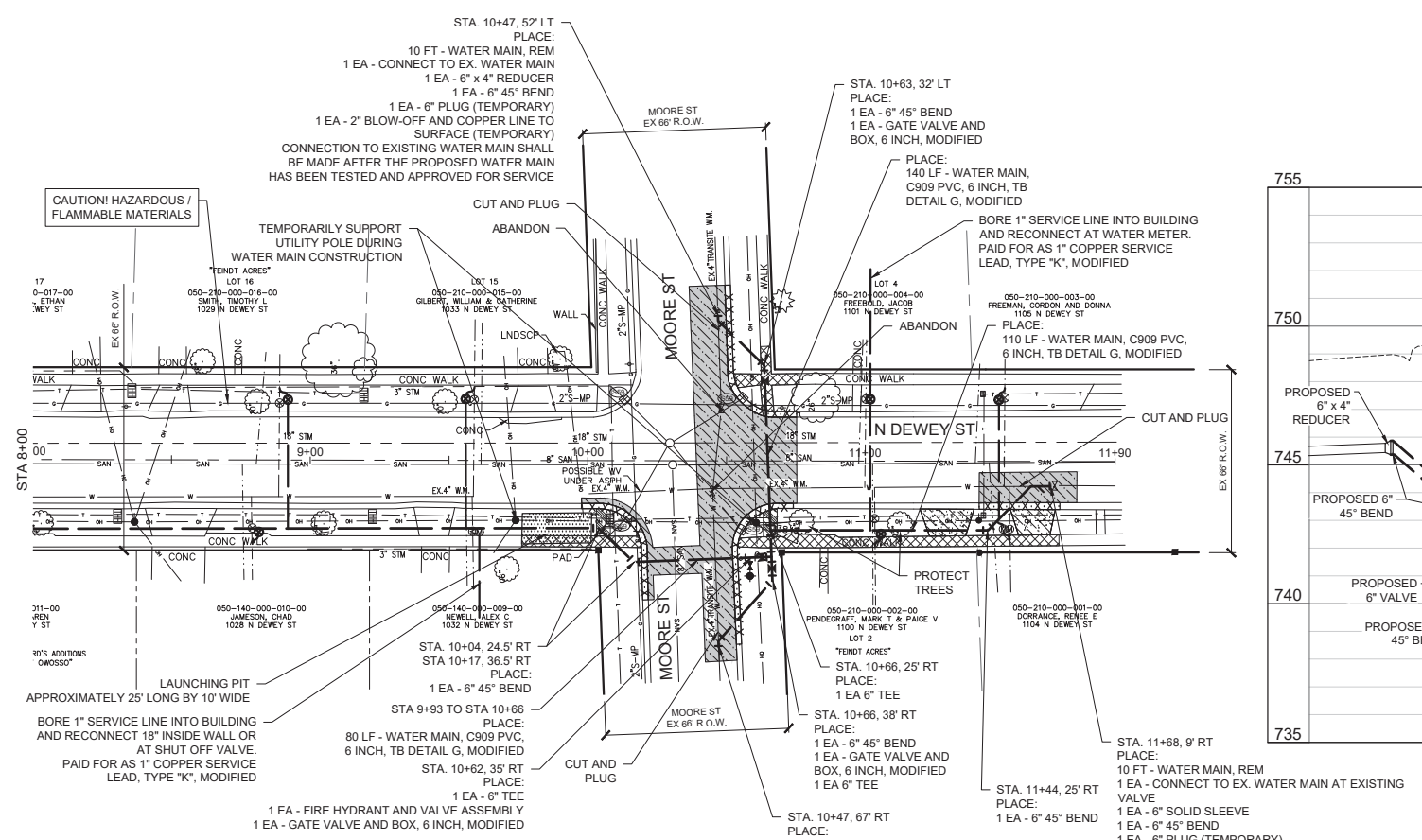
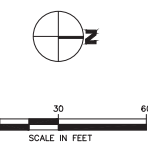

- LEGEND**
- WATER MAIN
  - - - WATER SERVICE LINE
  - ⊗ GATE VALVE AND BOX, \_INCH
  - REDUCER
  - ⊕ HYDRANT / VALVE
  - ⊙ CURB STOP
  - ⊙ METER PIT
  - ⊗ Curb and Gutter, Rem
  - X-X-X- Sewer, Rem
  - ▨ Pavt, Rem
  - ▨ Sidewalk, Rem and Sidewalk, Conc, \_\_\_ inch or Curb Ramp, Conc, \_\_\_ inch (Proposed sidewalk shall be 5' wide)
  - ▨ Curb and Gutter, Conc, Det F4, Modified
  - ▨ Sewer, SDR-26, \_\_\_ inch, Tr Det B, Modified
  - ▨ Aggregate Base, 8 inch, Modified and HMA, 13
  - ▨ Driveway, Nonreinf Conc, \_\_\_ inch
  - ▨ Approach, CI II, LM
  - ⊙ Bore Pit
  - ⊙ STANDARD SOIL EROSION KEY

CONSTRUCTION QUANTITIES (THIS SHEET)		
QUANTITY	UNIT	WORK ITEM
182	Ft	Curb and Gutter, Rem
383	Syd	Pavt, Rem
90	Syd	Sidewalk, Rem
4	Ea	Erosion Control, Inlet Protection, Fabric Drop
17	Cyd	Subbase, CIP
352	Syd	Aggregate Base, 8 inch, Modified
127	Ton	HMA, 13A
32	Syd	Driveway, Nonreinf Conc, 6 inch
182	Ft	Curb and Gutter, Conc, Det F4, Modified
30	Ft	Detectable Warning Surface, Modified
42	Ft	Curb Ramp Opening, Conc
275	Sft	Curb Ramp, Conc, 4 inch
273	Sft	Curb Ramp, Conc, 7 inch
282	Sft	Sidewalk, Conc, 4 inch
261	Sft	Sidewalk, Conc, 6 inch
500	Syd	Turf Establishment, Performance
3	Ea	Connect to Existing Water Main
30	Ft	Water Main, Rem
2	Ea	Existing Valve with Valve Box Abandonment
330	Ft	Water Main, C909 PVC, 6 inch, TB Detail G, Modified
193	Ft	Water Main, C909 PVC, 6 inch, Bore
3	Ea	Water Main, 4 inch, Cut and Plug, Modified
3	Ea	Gate Valve and Box, 6 inch, Modified
1	Ea	Fire Hydrant and Valve Assembly
405	Ft	1" Copper Service Lead, Type "K", Modified
8	Ea	Curb Box, Stop, 1 inch Corporation Stop and Connection, Modified
2	Ea	Supply & Install Meter Pit, Complete
2	Ea	Water Meter Pit, Rem

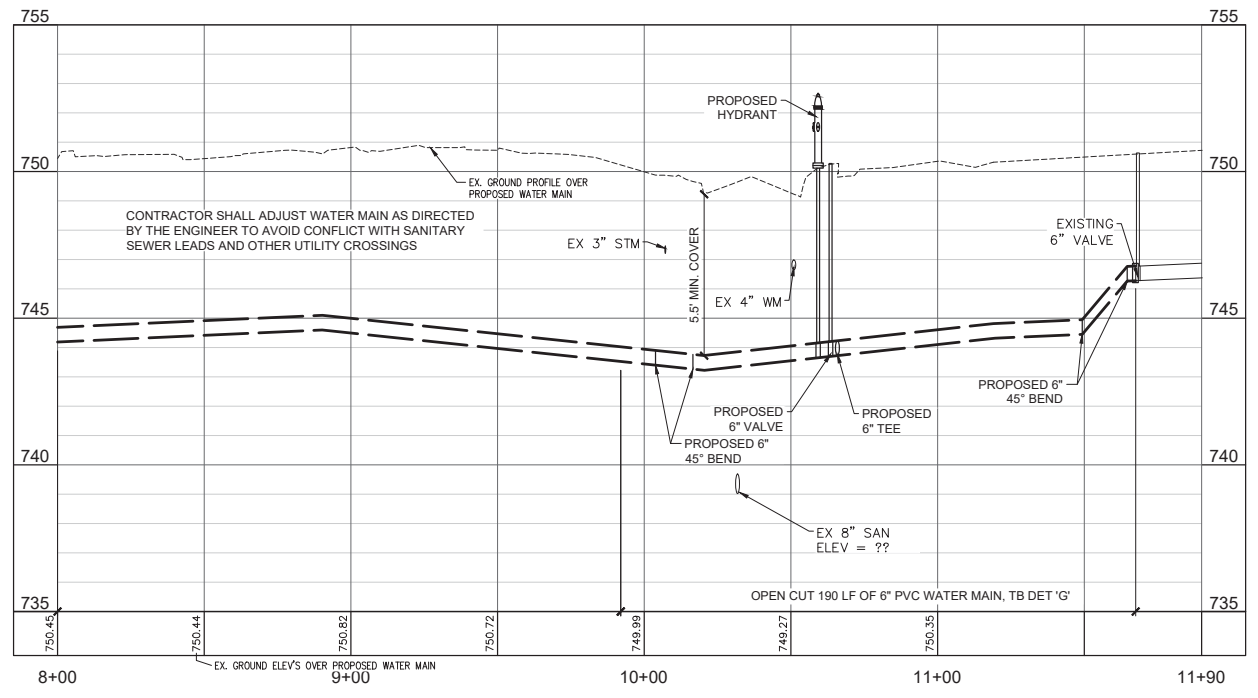

**CITY OF OWOSSO, MICHIGAN  
ENGINEERING DIVISION  
DEPT. OF PUBLIC SERVICE**

NO.	DATE	BY	REVISIONS		DESCRIPTION	CHECKED BY	APPROVED BY
			DATE	BY			
1	1/15/24	CW					

**DEWEY STREET  
WATER MAIN PLAN AND PROFILE**

2024 WATER MAIN REPLACEMENT PROJECT - DWSRF 7497-01

JANUARY, 2024  
PROJECT NO.

FIELD BOOK  
P.G.

DW3





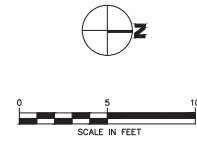
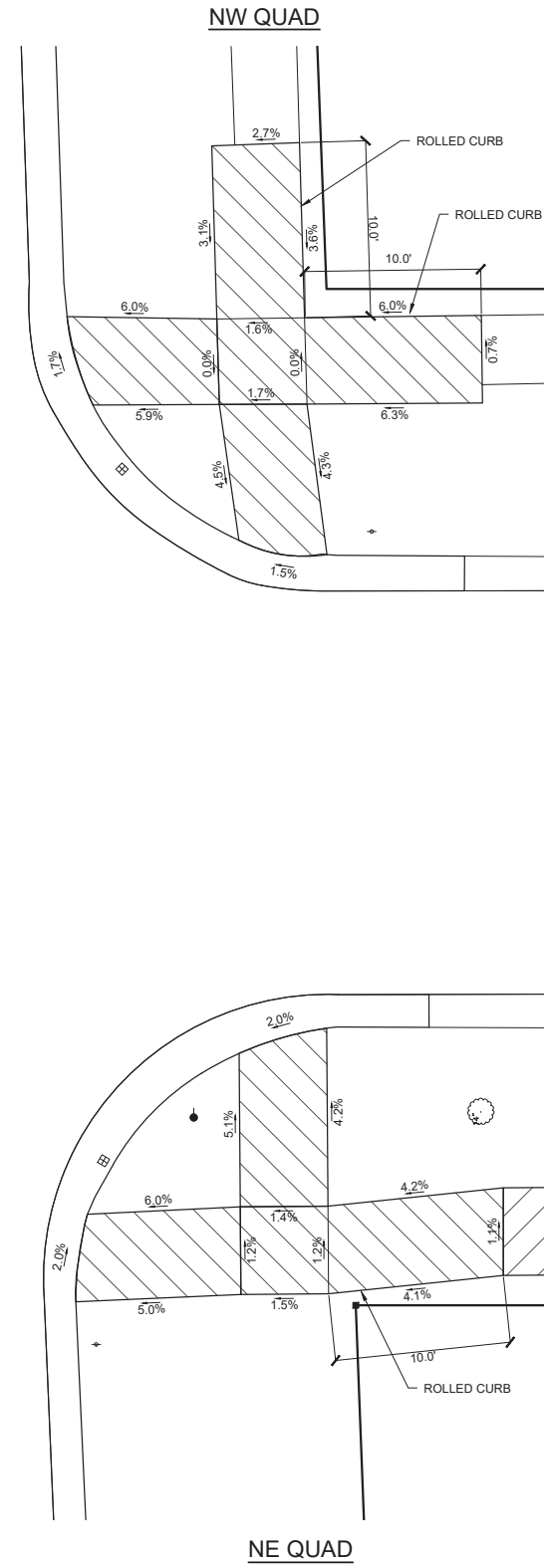
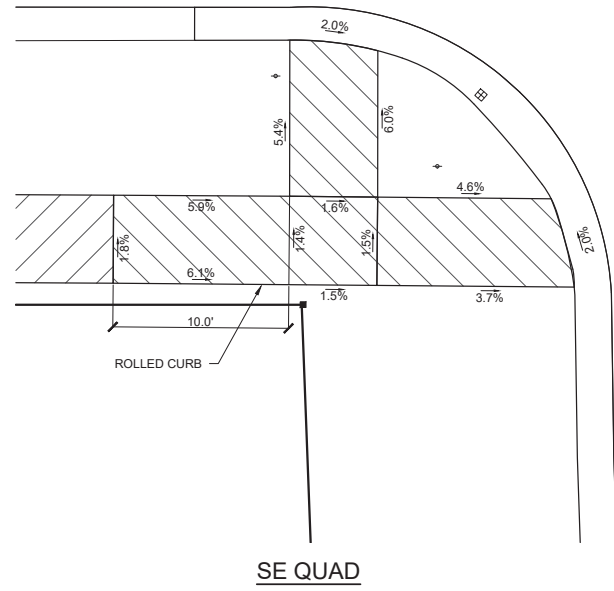

# SIDEWALK RAMP DETAIL AT MOORE ST

2024 WATER MAIN REPLACEMENT PROJECT - DWSRF 7497-01		BENCH MARK DATA		NO.		REVISIONS		DATE		BY	
DEWEY STREET		DESCRIPTION		1		IFB PLANS		1/15/24		CW	
SIDEWALK RAMP DETAIL		ELEV.									
JANUARY, 2024 PROJECT NO.		FIELD BOOK P.G.		CHECKED BY		ORIGINAL PLAN		APPROVED BY			
DW4											

CITY OF OWOSSO, MICHIGAN  
ENGINEERING DIVISION  
DEPT. OF PUBLIC SERVICE

# GRACE STREET CITY OF OWOSSO 2024 WATER MAIN REPLACEMENT PROJECT

SHEET NO.	DESCRIPTION
GR1	GRACE ST - COVER SHEET & TRAFFIC CONTROL PLAN
GR2-GR3	GRACE ST - WATER MAIN PLAN AND PROFILE
GR4	GRACE ST - SIDEWALK RAMP DETAIL

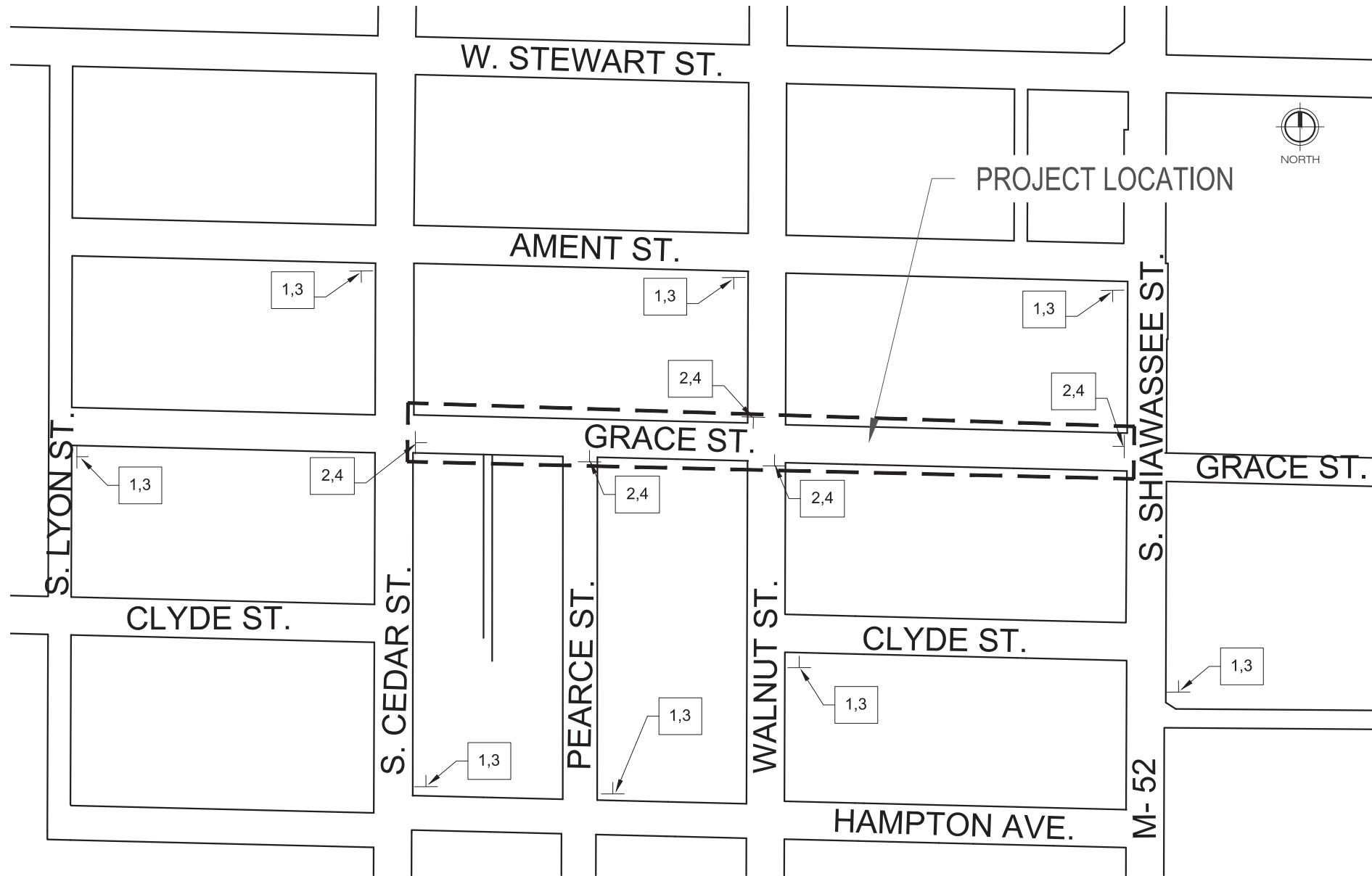

SIGNING REQUIREMENTS					
NO.	SIGN	SIGN DESIGNATION	SIZE	NO. REQ.	TOTAL AREA (SFT)
1		W20-1	48 x 48	8	128
2		R11-3A	60 x 30	5	63
3		M4-8 MOD	30 X 8	8	14
4		TYPE III BARRICADE		5	

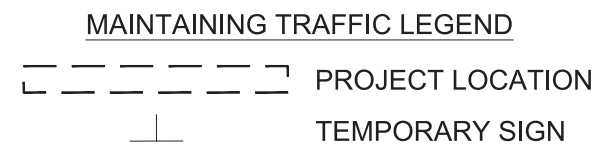

CITY OF OWOSSO, MICHIGAN  
 ENGINEERING DIVISION  
 DEPT. OF PUBLIC SERVICE

NO.	IFB PLANS	REVISIONS	DATE	BY
1			1/15/24	CW

BENCH MARK DATA  
 ELEV.      DESCRIPTION

CHECKED BY      APPROVED BY

2024 WATER MAIN REPLACEMENT PROJECT - DWSRF 7497-01

GRACE STREET  
 COVER SHEET & TRAFFIC CONTROL PLAN

JANUARY, 2024  
 PROJECT NO.

FIELD BOOK  
 P.G.

GR1

BM 11911 738.54  
LAG BOLT IN EAST SIDE OF POWER POLE, NORTH SIDE OF GRACE ST AT PEARCE ST (NAVD 88)

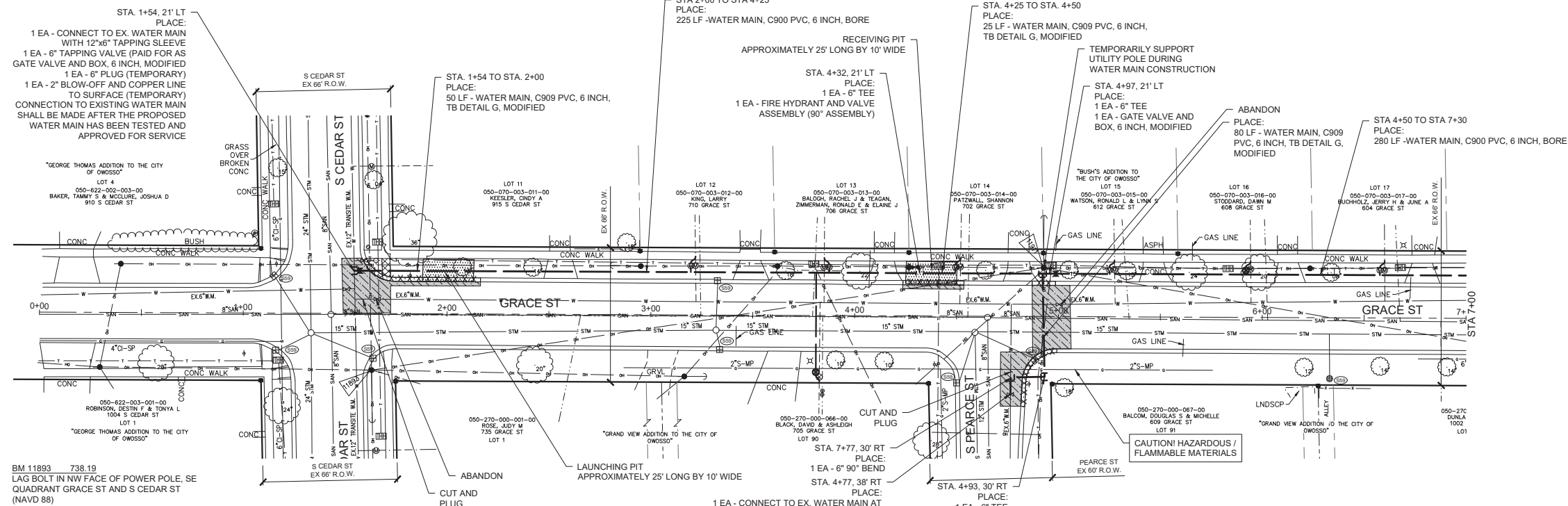
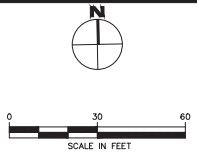

- LEGEND**
- WATER MAIN
  - WATER SERVICE LINE
  - ✕ GATE VALVE AND BOX, \_INCH
  - ▶ REDUCER
  - ⦿ HYDRANT / VALVE
  - ⊙ CURB STOP
  - ⊙ METER PIT
  - ▭ Curb and Gutter, Rem
  - X-X-X- Sewer, Rem
  - ▨ Pavt, Rem
  - ▨ Sidewalk, Rem and Sidewalk, Conc, \_inch or Curb Ramp, Conc, \_inch (Proposed sidewalk shall be 5' wide)
  - ▨ Curb and Gutter, Conc, Det F4, Modified
  - ▨ Sewer, SDR-26, \_inch, Tr Det B, Modified
  - ▨ Aggregate Base, 8 inch, Modified and HMA, 13
  - ▨ Driveway, Nonreinf Conc, \_inch
  - ▨ Approach, CI II, LM
  - ⊙ Bore Pit
  - ⊙ STANDARD SOIL EROSION KEY

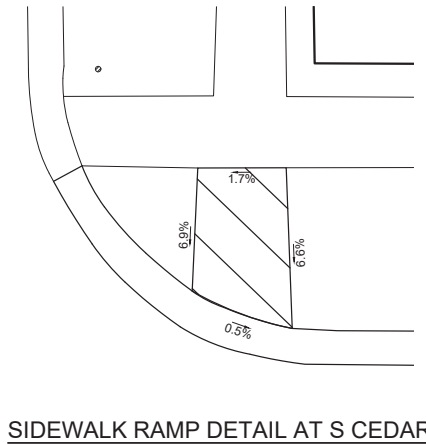

**GRACE STREET WATER MAIN PLAN**

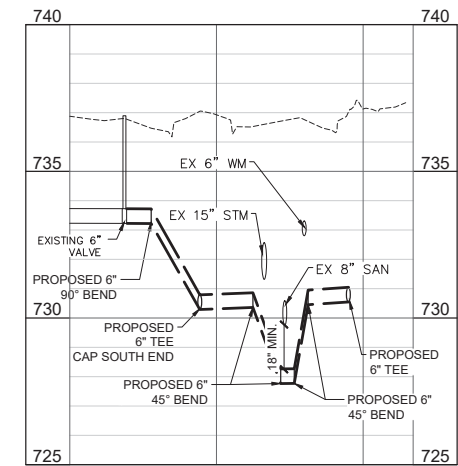

**CONSTRUCTION QUANTITIES (THIS SHEET)**

QUANTITY	UNIT	WORK ITEM
127	Ft	Curb and Gutter, Rem
177	Syd	Pavt, Rem
4	Syd	Sidewalk, Rem
8	Ea	Erosion Control, Inlet Protection, Fabric Drop
1	Cyd	Subbase, CIP
177	Syd	Aggregate Base, 8 inch, Modified
64	Ton	HMA, 13A
127	Ft	Curb and Gutter, Conc, Det F4, Modified
5	Ft	Detectable Warning Surface, Modified
7	Ft	Curb Ramp Opening, Conc
45	Sft	Curb Ramp, Conc, 7 inch
250	Syd	Turf Establishment, Performance
2	Ea	Connect to Existing Water Main
10	Ft	Water Main, Rem
2	Ea	Existing Valve with Valve Box Abandonment
155	Ft	Water Main, C909 PVC, 6 inch, TB Detail G, Modified
475	Ft	Water Main, C900 PVC, 6 inch, Bore
2	Ea	Water Main, 6 inch, Cut and Plug, Modified
2	Ea	Gate Valve and Box, 6 inch, Modified
1	Ea	Fire Hydrant and Valve Assembly
145	Ft	1" Copper Service Lead, Type "K", Modified
7	Ea	Curb Box, Stop, 1 inch Corporation Stop and Connection, Modified
5	Ea	Supply & Install Meter Pit, Complete
5	Ea	Water Meter Pit, Rem

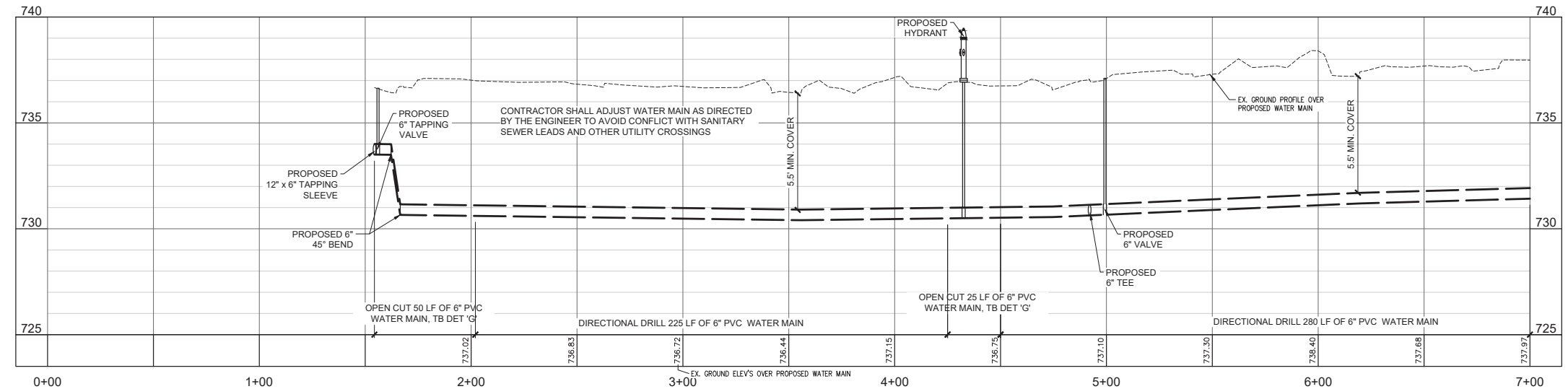

**CITY OF OWOSSO, MICHIGAN**  
**ENGINEERING DIVISION**  
**DEPT. OF PUBLIC SERVICE**

NO.	1	IFB PLANS
REVISIONS		
DATE	1/15/24	CW
BY		
APPROVED BY		

BENCH MARK DATA  
 ELEV.

DESCRIPTION

CHECKED BY

ORIGINAL PLAN

2024 WATER MAIN REPLACEMENT PROJECT - DWSRF 7497-01  
 GRACE STREET  
 WATER MAIN PLAN AND PROFILE  
 JANUARY, 2024  
 PROJECT NO.

FIELD BOOK  
 P.G.

**GR2**



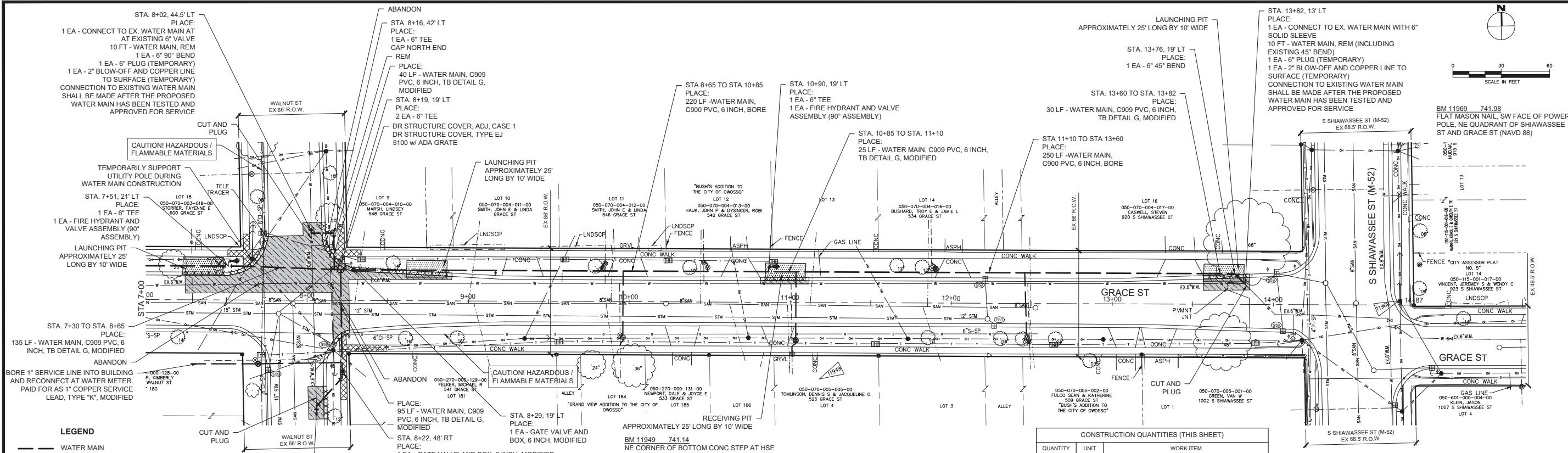
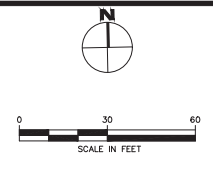

**LEGEND**

- WATER MAIN
- WATER SERVICE LINE
- ✕ GATE VALVE AND BOX, \_INCH
- ▶ REDUCER
- ⊕ HYDRANT / VALVE
- CURB STOP
- ⊙ METER PIT
- ▨ Curb and Gutter, Rem
- ▨ Sewer, Rem
- ▨ Pavt, Rem
- ▨ Sidewalk, Rem and Sidewalk, Conc, \_inch or Curb Ramp, Conc, \_inch (Proposed sidewalk shall be 5' wide)
- ▨ Curb and Gutter, Conc, Det F4, Modified
- ▨ Sewer, SDR-26, \_inch, Tr Det B, Modified
- ▨ Aggregate Base, 8 inch, Modified and HMA, 13
- ▨ Driveway, Nonreinf Conc, \_inch
- ▨ Approach, CI II, LM
- Bore Pit
- STANDARD SOIL EROSION KEY

**CONSTRUCTION QUANTITIES (THIS SHEET)**

QUANTITY	UNIT	WORK ITEM
254	Ft	Curb and Gutter, Rem
366	Syd	Pavt, Rem
62	Syd	Sidewalk, Rem
7	Ea	Erosion Control, Inlet Protection, Fabric Drop
8	Cyd	Subbase, CIP
366	Syd	Aggregate Base, 8 inch, Modified
1	Ea	Dr Structure Cover, Adj, Case 1
1	Ea	Dr Structure Cover, Type EJ 5100 w/ ADA grate
133	Ton	HMA, 13A
254	Ft	Curb and Gutter, Conc, Det F4, Modified
20	Ft	Detectable Warning Surface, Modified
28	Ft	Curb Ramp Opening, Conc
543	Sft	Curb Ramp, Conc, 4 inch
102	Sft	Curb Ramp, Conc, 7 inch
450	Syd	Turf Establishment, Performance
3	Ea	Connect to Existing Water Main
30	Ft	Water Main, Rem
2	Ea	Existing Valve with Valve Box Abandonment
1	Ea	Hydrant, Rem
325	Ft	Water Main, C909 PVC, 6 inch, TB Detail G, Modified
500	Ft	Water Main, C900 PVC, 6 inch, Bore
3	Ea	Water Main, 6 inch, Cut and Plug, Modified
2	Ea	Gate Valve and Box, 6 inch, Modified
2	Ea	Fire Hydrant and Valve Assembly
355	Ft	1" Copper Service Lead, Type "K", Modified
7	Ea	Curb Box, Stop, 1 inch Corporation Stop and Connection, Modified
4	Ea	Supply & Install Meter Pit, Complete
4	Ea	Water Meter Pit, Rem

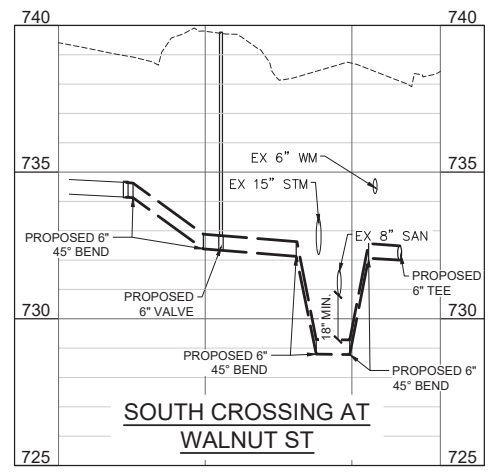
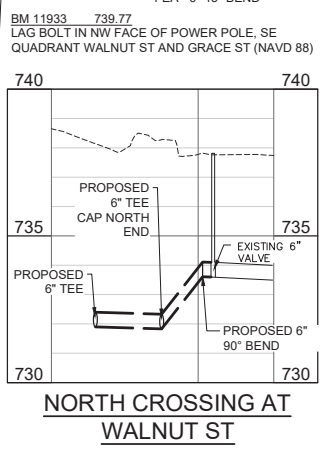

**GRACE STREET WATER MAIN PLAN**

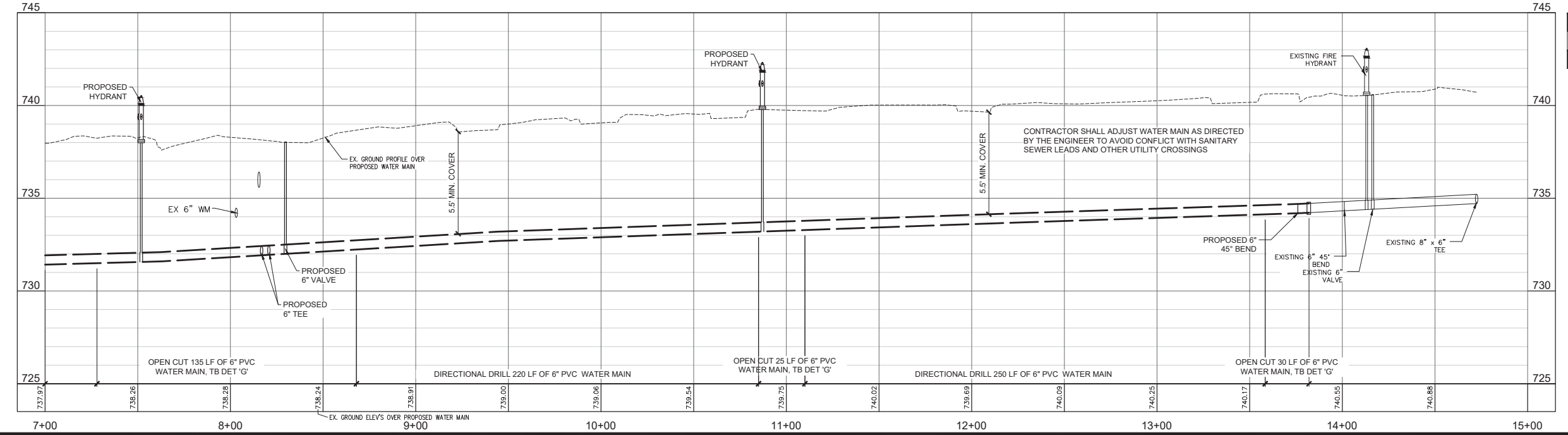

**BENCH MARK DATA**

NO.	DATE	BY	REVISIONS	DESCRIPTION
1	1/15/24	CW		IFB PLANS

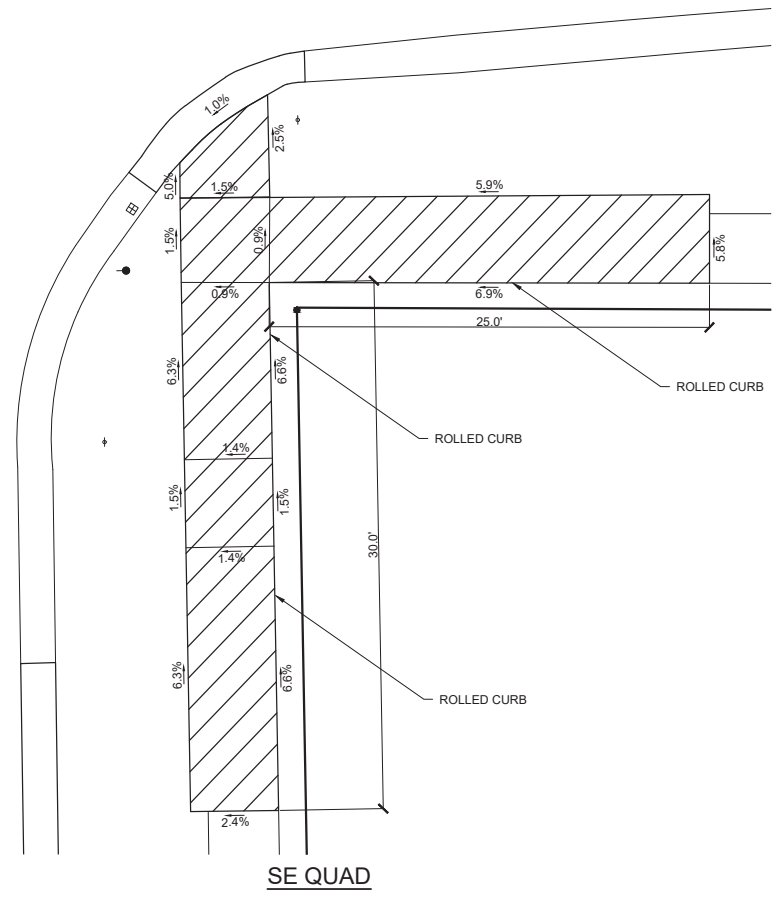
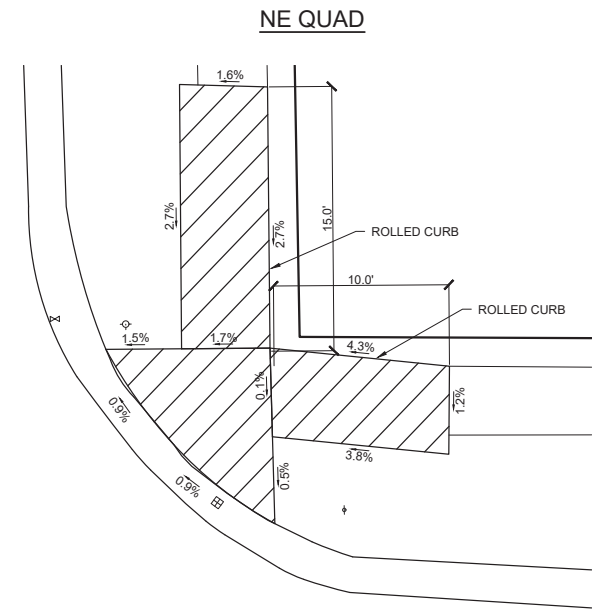
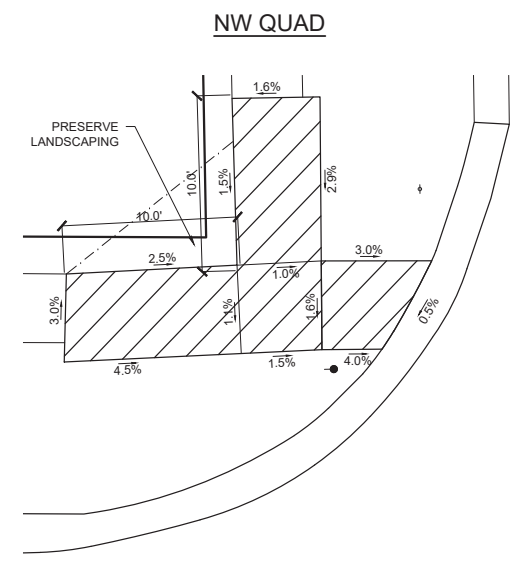
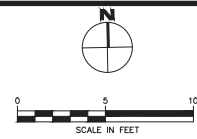

# SIDEWALK RAMP DETAIL AT WALNUT ST

2024 WATER MAIN REPLACEMENT PROJECT - DWSRF 7497-01		BENCH MARK DATA		NO.		REVISIONS		DATE		BY	
GRACE STREET		ELEV.		1		IFB PLANS		1/15/24		CW	
SIDEWALK RAMP DETAIL		DESCRIPTION									
JANUARY, 2024											
PROJECT NO.										APPROVED BY	
										ORIGINAL PLAN	
										CHECKED BY	
										APPROVED BY	
										FIELD BOOK	
										P.G.	

CITY OF OWOSSO, MICHIGAN  
 ENGINEERING DIVISION  
 DEPT. OF PUBLIC SERVICE

GR4

# TRACY STREET CITY OF OWOSSO 2024 WATER MAIN REPLACEMENT PROJECT

SHEET NO.	DESCRIPTION
TR1	TRACY ST - COVER SHEET & TRAFFIC CONTROL PLAN
TR2-TR3	TRACY ST - WATER MAIN PLAN AND PROFILE



SIGNING REQUIREMENTS					
NO.	SIGN	SIGN DESIGNATION	SIZE	NO. REQ.	TOTAL AREA (SFT)
1		W20-1	48 x 48	7	112
2		R11-3A	60 x 30	4	50
3		M4-8 MOD	30 X 8	7	12
4		TYPE III BARRICADE		4	

### MAINTAINING TRAFFIC LEGEND

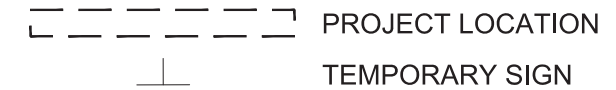

THE EASTBOUND SHOULDER ON STEWART STREET NORTH OF TRACY STREET SHALL BE CLOSED DURING THE WATER MAIN TIE-IN AND ASSOCIATED WORK IN ACCORDANCE WITH MDOT MAINTAINING TRAFFIC TYPICAL 122-NFW-SHL-(R). QUANTITIES FOR THIS CLOSURE ARE INCLUDED IN THE MAINTAINING TRAFFIC QUANTITIES TABLE ON THE WATER MAIN NOTES AND DETAILS SHEET.

CITY OF OWOSSO, MICHIGAN  
ENGINEERING DIVISION  
DEPT. OF PUBLIC SERVICE

NO.	DATE	BY	DESCRIPTION
1	1/15/24	CW	IFB PLANS
			REVISIONS

BENCH MARK DATA  
ELEV.

CHECKED BY  
APPROVED BY

2024 WATER MAIN REPLACEMENT PROJECT - DWSRF 7497-01  
TRACY STREET  
COVER SHEET & TRAFFIC CONTROL PLAN

JANUARY, 2024  
PROJECT NO.

FIELD BOOK  
P.G.

TR1



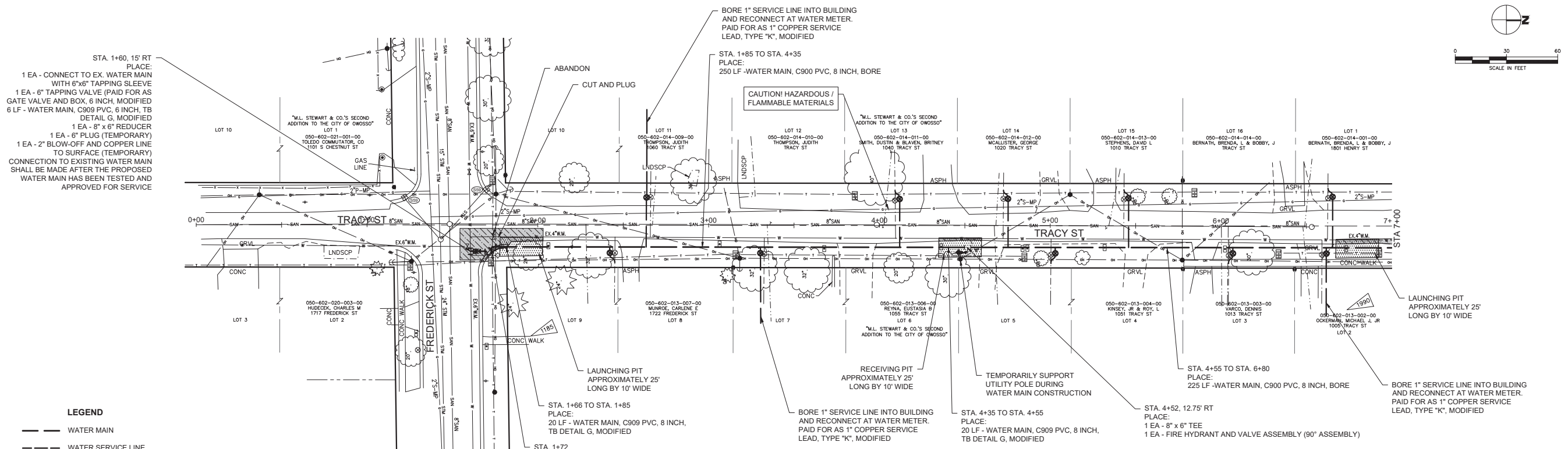

- LEGEND**
- WATER MAIN
  - - - WATER SERVICE LINE
  - ⊗ GATE VALVE AND BOX, \_\_\_ INCH
  - ▶ REDUCER
  - ◆ HYDRANT / VALVE
  - ⊙ CURB STOP
  - ⊕ METER PIT
  - ▨ Curb and Gutter, Rem
  - X-X-X- Sewer, Rem
  - ▨ Pavt, Rem
  - ▨ Sidewalk, Rem and Sidewalk, Conc, \_\_\_ inch or Curb Ramp, Conc, \_\_\_ inch (Proposed sidewalk shall be 5' wide)
  - ▨ Curb and Gutter, Conc, Det F4, Modified
  - ▨ Sewer, SDR-26, \_\_\_ inch, Tr Det B, Modified
  - ▨ Aggregate Base, 8 inch, Modified and HMA, 13
  - ▨ Driveway, Nonreinf Conc, \_\_\_ inch
  - ▨ Approach, CI II, LM
  - ⊙ Bore Pit
  - ⊙ STANDARD SOIL EROSION KEY

**TRACY STREET**  
WATER MAIN PLAN

CONSTRUCTION QUANTITIES (THIS SHEET)		
QUANTITY	UNIT	WORK ITEM
18	Ft	Curb and Gutter, Rem
81	Syd	Pavt, Rem
2	Ea	Erosion Control, Inlet Protection, Fabric Drop
81	Syd	Aggregate Base, 8 inch, Modified
29	Ton	HMA, 13A
18	Ft	Curb and Gutter, Conc, Det F4, Modified
200	Syd	Turf Establishment, Performance
1	Ea	Connect to Existing Water Main
1	Ea	Existing Valve with Valve Box Abandonment
6	Ft	Water Main, C909 PVC, 6 inch, TB Detail G, Modified
60	Ft	Water Main, C909 PVC, 8 inch, TB Detail G, Modified
475	Ft	Water Main, C900 PVC, 8 inch, Bore
1	Ea	Water Main, 4 inch, Cut and Plug, Modified
1	Ea	Gate Valve and Box, 6 inch, Modified
1	Ea	Fire Hydrant and Valve Assembly
400	Ft	1" Copper Service Lead, Type "K", Modified
10	Ea	Curb Box, Stop, 1 inch Corporation Stop and Connection, Modified

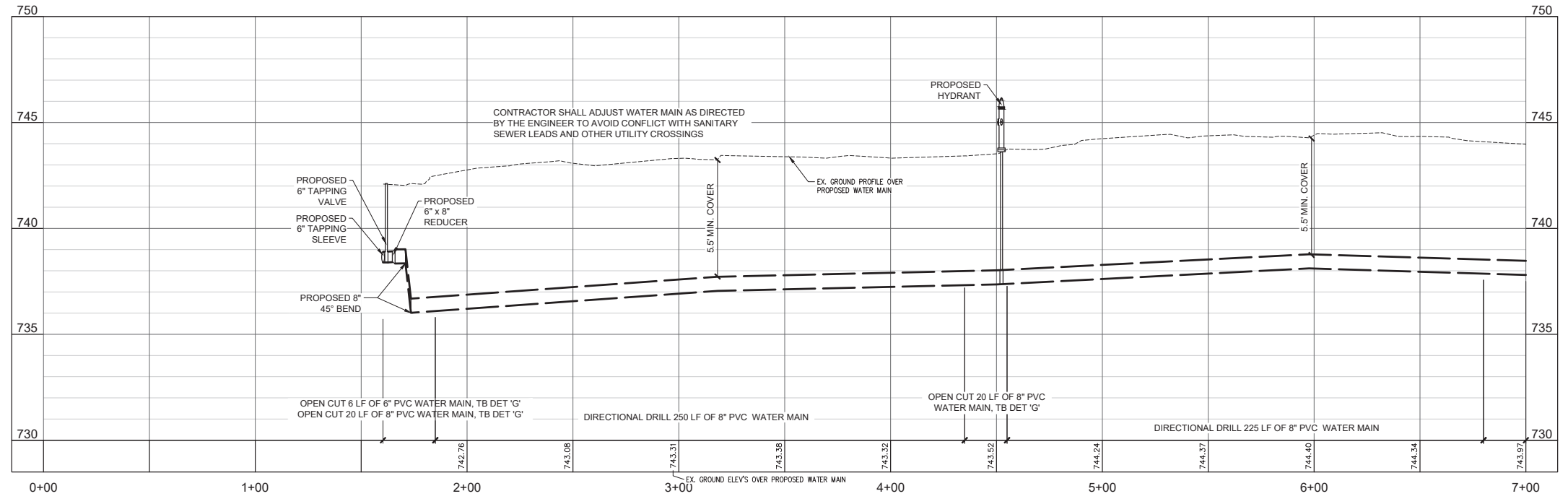

CITY OF OWOSSO, MICHIGAN  
ENGINEERING DIVISION  
DEPT. OF PUBLIC SERVICE

NO.	DATE	BY	REVISIONS
1	1/15/24	CW	

NO.	DESCRIPTION	CHECKED BY	APPROVED BY
1	IFB PLANS		

2024 WATER MAIN REPLACEMENT PROJECT - DWSRF 7497-01  
TRACY STREET  
WATER MAIN PLAN AND PROFILE  
JANUARY, 2024  
PROJECT NO.

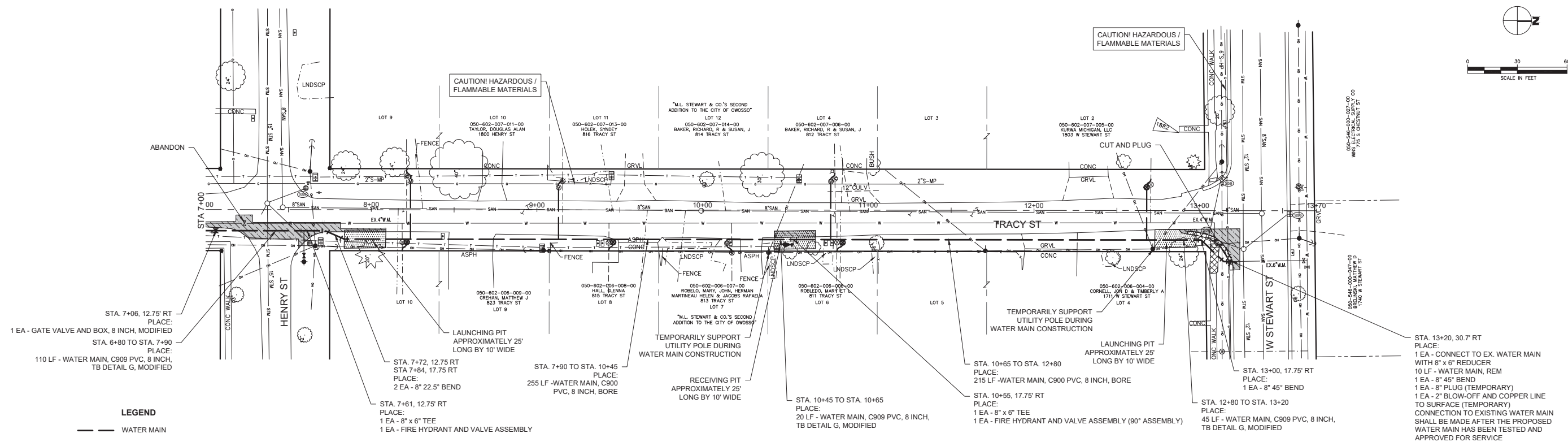
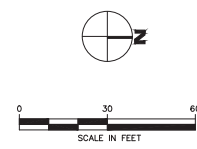

- LEGEND**
- WATER MAIN
  - - - WATER SERVICE LINE
  - ✕ GATE VALVE AND BOX, .INCH
  - REDUCER
  - ◆ HYDRANT / VALVE
  - ⊙ CURB STOP
  - ⊙ METER PIT
  - ▨ Curb and Gutter, Rem
  - X-X-X- Sewer, Rem
  - ▨ Pavt, Rem
  - ▨ Sidewalk, Rem and Sidewalk, Conc, . inch or Curb Ramp, Conc, . inch (Proposed sidewalk shall be 5' wide)
  - ▨ Curb and Gutter, Conc, Det F4, Modified
  - X-X-X- Sewer, SDR-26, . inch, Tr Det B, Modified
  - ▨ Aggregate Base, 8 inch, Modified and HMA, 13
  - ▨ Driveway, Nonreinf Conc, . inch
  - ▨ Approach, CI II, LM
  - ▨ Bore Pit
  - ⊙ STANDARD SOIL EROSION KEY

**TRACY STREET**  
WATER MAIN PLAN

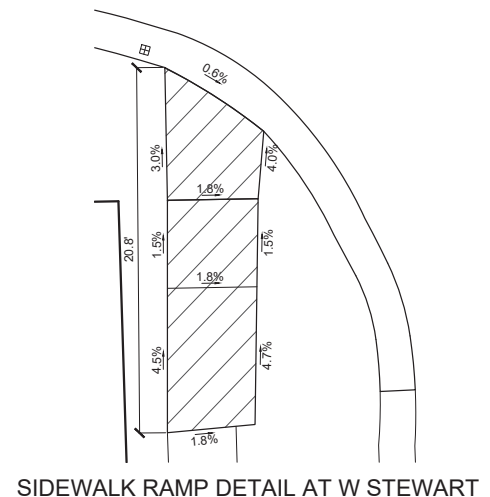

**CONSTRUCTION QUANTITIES (THIS SHEET)**

QUANTITY	UNIT	WORK ITEM
38	Ft	Curb and Gutter, Rem
122	Syd	Pavt, Rem
11	Syd	Sidewalk, Rem
4	Ea	Erosion Control, Inlet Protection, Fabric Drop
2	Cyd	Subbase, CIP
122	Syd	Aggregate Base, 8 inch, Modified
44	Ton	HMA, 13A
38	Ft	Curb and Gutter, Conc, Det F4, Modified
5	Ft	Detectable Warning Surface, Modified
7	Ft	Curb Ramp Opening, Conc
66	Sft	Curb Ramp, Conc, 4 inch
32	Sft	Curb Ramp, Conc, 7 inch
300	Syd	Turf Establishment, Performance
1	Ea	Connect to Existing Water Main
10	Ft	Water Main, Rem
1	Ea	Existing Valve with Valve Box Abandonment
155	Ft	Water Main, C909 PVC, 8 inch, TB Detail G, Modified
470	Ft	Water Main, C900 PVC, 8 inch, Bore
1	Ea	Water Main, 4 inch, Cut and Plug, Modified
1	Ea	Gate Valve and Box, 8 inch, Modified
2	Ea	Fire Hydrant and Valve Assembly
220	Ft	1" Copper Service Lead, Type "K", Modified
8	Ea	Curb Box, Stop, 1 inch Corporation Stop and Connection, Modified
4	Ea	Supply & Install Meter Pit, Complete
4	Ea	Water Meter Pit, Rem

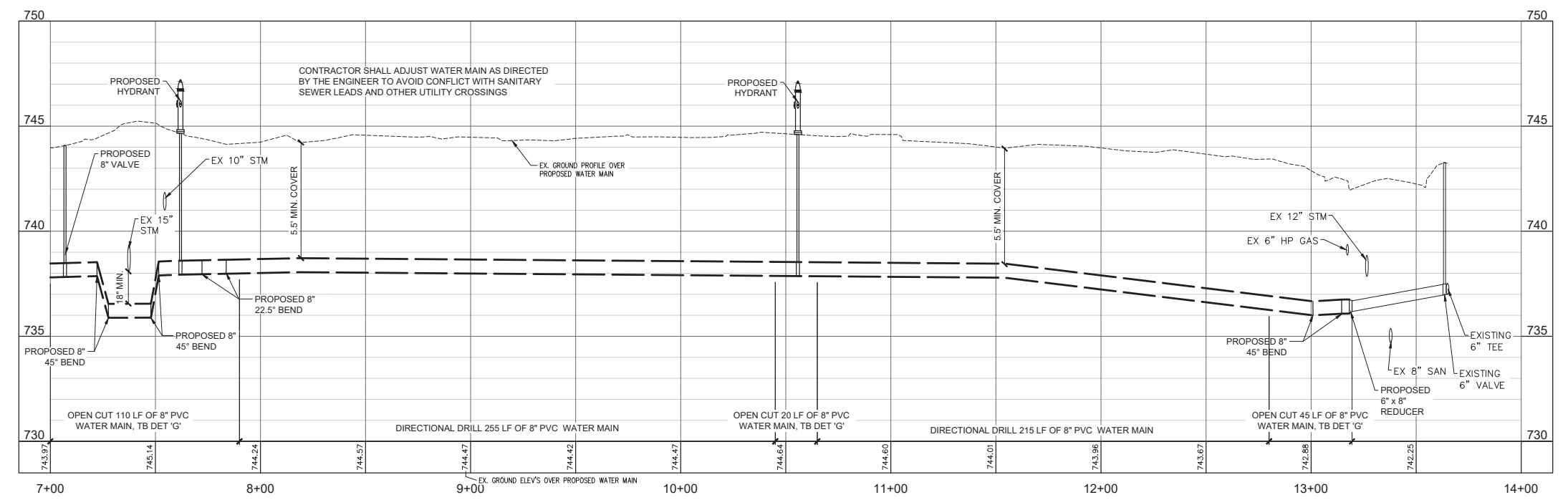

NO.	DATE	BY	DESCRIPTION
1	1/15/24	CW	IFB PLANS

NO.	DATE	BY	DESCRIPTION
1	1/15/24	CW	IFB PLANS

  

NO.	DATE	BY	DESCRIPTION
1	1/15/24	CW	IFB PLANS





BM 2422 755.04  
SE CORNER OF BOTTOM STEP, HSE #1616  
(NAVD 88)

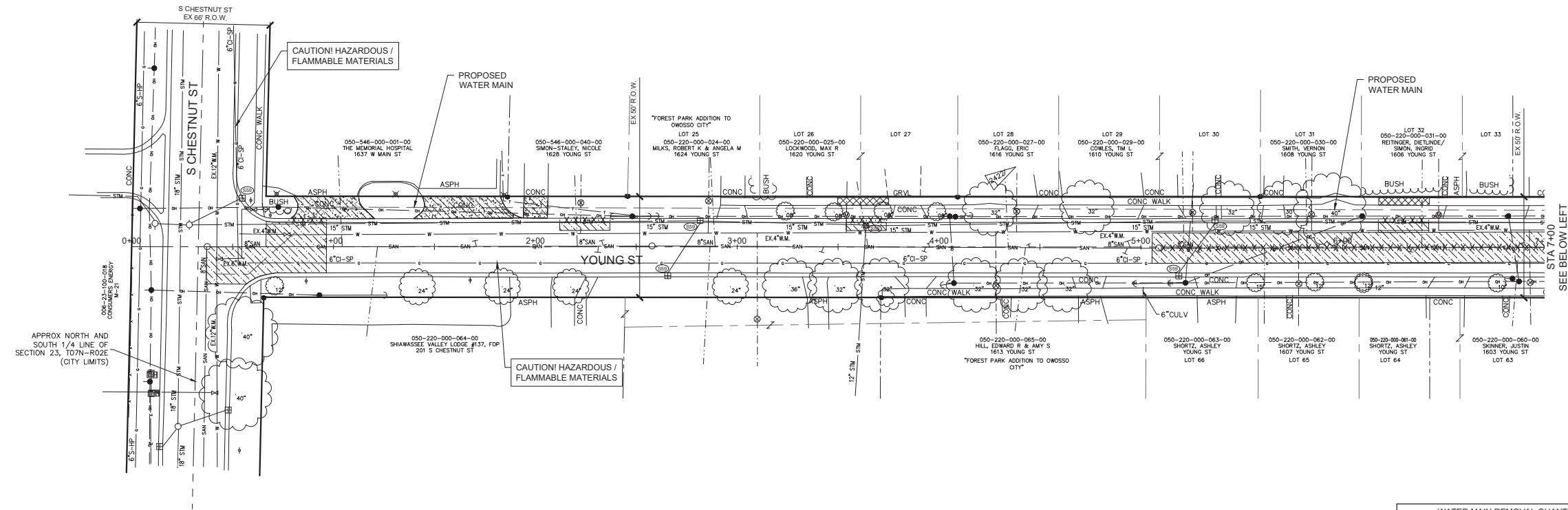
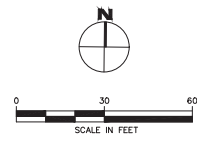

**LEGEND**

- ▣ Curb and Gutter, Rem
- X-X-X- Sewer, Rem
- ▨ Pavt, Rem
- ▩ Sidewalk, Rem
- STANDARD SOIL EROSION KEY

**YOUNG STREET  
REMOVAL PLAN**

WATER MAIN REMOVAL QUANTITIES (THIS SHEET)		
QUANTITY	UNIT	WORK ITEM
247	Ft	Curb and Gutter, Rem
430	Syd	Pavt, Rem
85	Syd	Sidewalk, Rem
11	Ea	Erosion Control, Inlet Protection, Fabric Drop

SANITARY SEWER REMOVAL QUANTITIES (THIS SHEET)		
QUANTITY	UNIT	WORK ITEM
276	Ft	Sewer, Rem, Less than 24 inch
475	Syd	Pavt, Rem

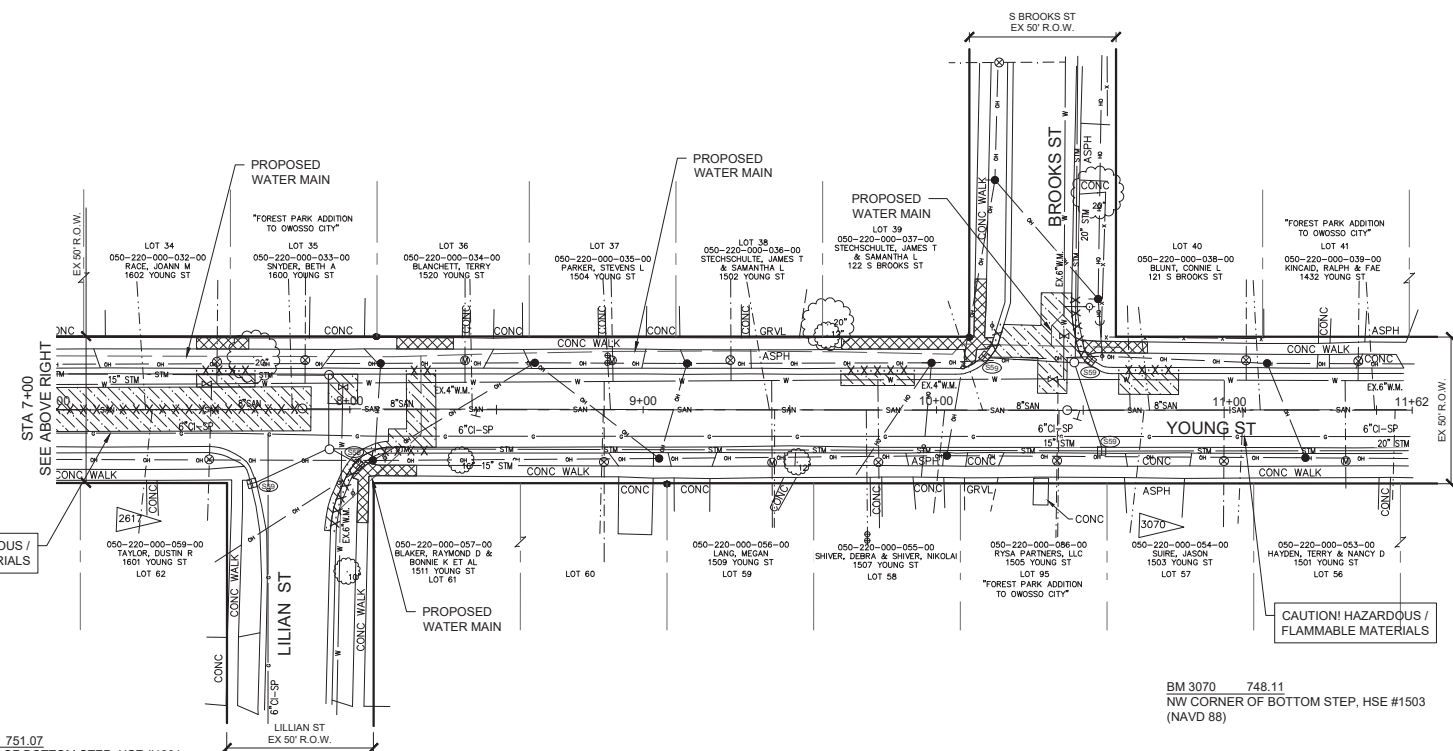

BM 2617 751.07  
NE CORNER OF BOTTOM STEP, HSE #1601  
(NAVD 88)

BM 3070 748.11  
NW CORNER OF BOTTOM STEP, HSE #1503  
(NAVD 88)

NO.	IFB PLANS	REVISIONS	DATE	BY
1			1/15/24	CW

BENCH MARK DATA	DESCRIPTION	ELEV.

2024 WATER MAIN REPLACEMENT PROJECT - DWSRF 7497-01	PROJECT NO.	P.G.
YOUNG STREET REMOVAL PLAN		

CITY OF OWOSSO, MICHIGAN  
ENGINEERING DIVISION  
DEPT. OF PUBLIC SERVICE

APPROVED BY

CHECKED BY

ORIGINAL PLAN

JANUARY, 2024  
PROJECT NO.

YN2

BM 2422 755.04  
SE CORNER OF BOTTOM STEP, HSE #1616  
(NAVD 88)

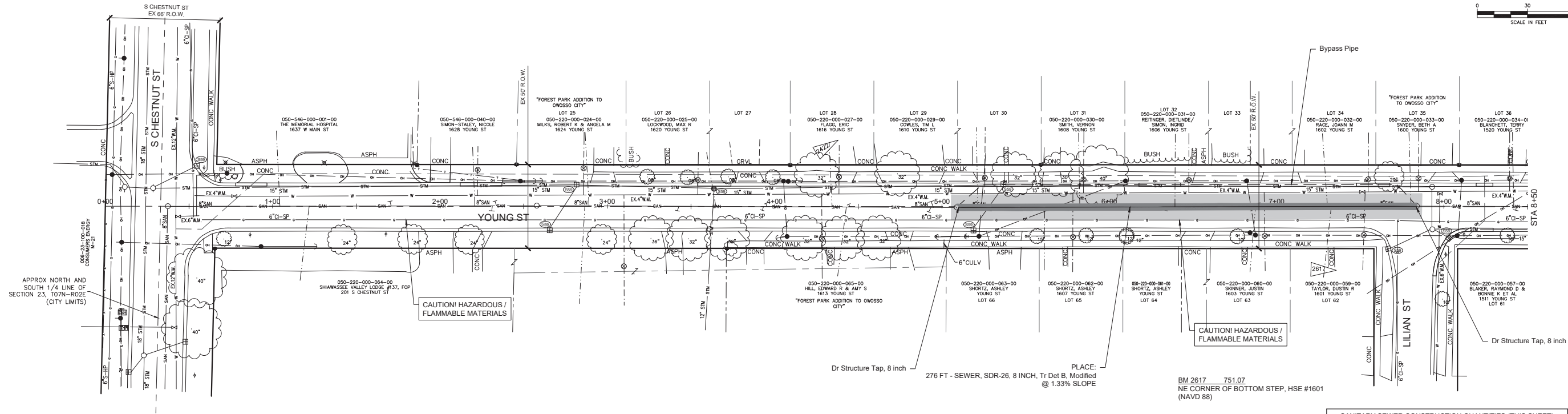
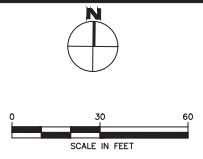

APPROX NORTH AND SOUTH 1/4 LINE OF SECTION 23, T07N-R02E (CITY LIMITS)

CAUTION! HAZARDOUS / FLAMMABLE MATERIALS

CAUTION! HAZARDOUS / FLAMMABLE MATERIALS

Dr Structure Tap, 8 inch  
276 FT - SEWER, SDR-26, 8 INCH, Tr Det B, Modified @ 1.33% SLOPE

BM 2617 751.07  
NE CORNER OF BOTTOM STEP, HSE #1601  
(NAVD 88)

SANITARY SEWER CONSTRUCTION QUANTITIES (THIS SHEET)		
QUANTITY	UNIT	WORK ITEM
175	Ton	Maintenance Gravel
475	Syd	Aggregate Base, 8 inch, Modified
276	Ft	Sewer, SDR-26, 8 inch, Tr Det B, Modified
2	Ea	Dr Structure Tap, 8 inch
1	LSUM	Sanitary Sewer, Bypass Pumping
175	Ton	HMA, 13A

- LEGEND**
- Sewer, SDR-26, \_\_\_ inch, Tr Det B, Modified
  - Sewer Bypass Pumping Pipe
  - Aggregate Base, 8 inch, Modified and HMA, 13
  - STANDARD SOIL EROSION KEY

**YOUNG STREET**  
SANITARY SEWER PLAN

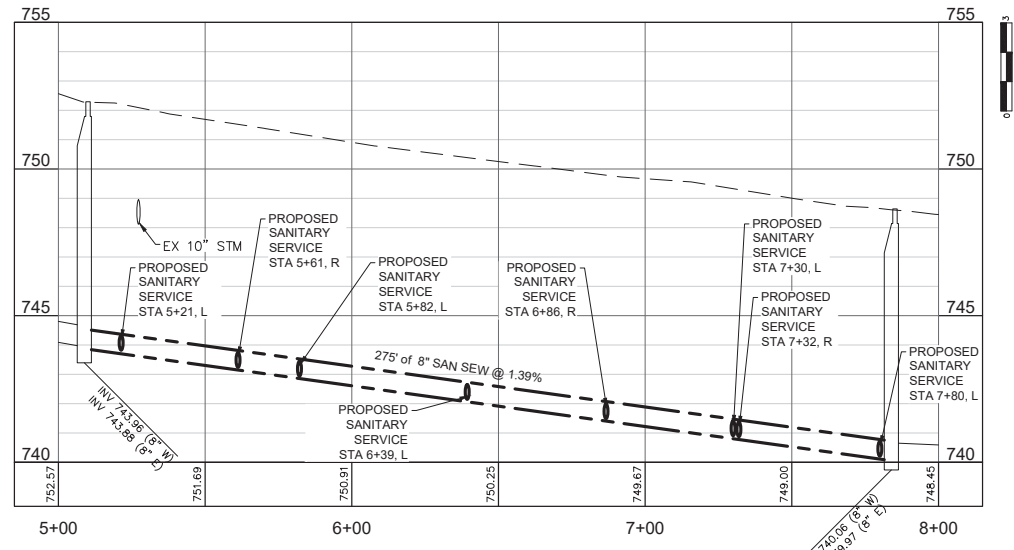

**CITY OF OWOSSO, MICHIGAN**  
**ENGINEERING DIVISION**  
**DEPT. OF PUBLIC SERVICE**

NO.	DATE	BY	REVISIONS
1	1/15/24	CW	IFB PLANS

NO.	DESCRIPTION	CHECKED BY	APPROVED BY

2024 WATER MAIN REPLACEMENT PROJECT - DWSRF 7497-01

**YOUNG STREET**  
SANITARY SEWER PLAN AND PROFILE

JANUARY, 2024  
PROJECT NO. **YN3**

FIELD BOOK P.G.

BM 2422 755.04  
SE CORNER OF BOTTOM STEP, HSE #1616  
(NAVD 88)

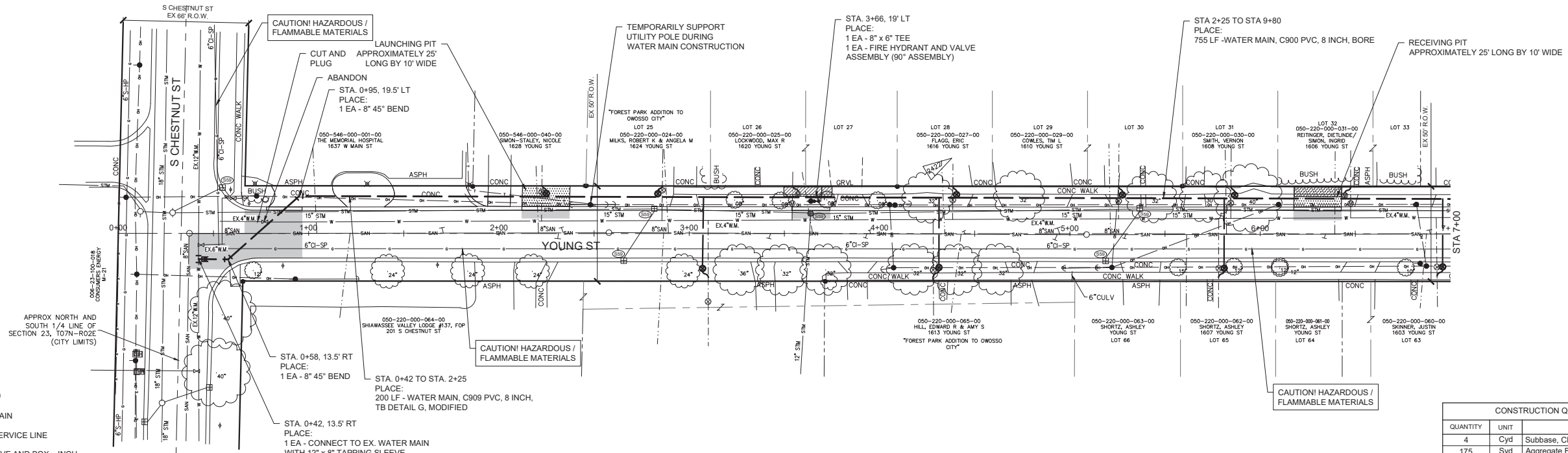
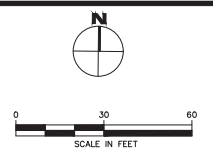

- LEGEND**
- WATER MAIN
  - - - WATER SERVICE LINE
  - ✕ GATE VALVE AND BOX, \_INCH
  - ▶ REDUCER
  - ⊕ HYDRANT / VALVE
  - CURB STOP
  - ⊙ METER PIT
  - ▨ Curb Ramp, Conc, \_inch
  - ▨ Sidewalk, Conc, \_inch
  - ▨ Aggregate Base, 8 inch, Modified and HMA, 13
  - ▨ Driveway, Nonreinf Conc, \_inch
  - ▨ Approach, CI II, LM
  - ▨ Bore Pit
  - ⊙ STANDARD SOIL EROSION KEY

STA. 0+42, 13.5' RT  
PLACE:  
1 EA - CONNECT TO EX. WATER MAIN WITH 12" x 8" TAPPING SLEEVE  
1 EA - 8" TAPPING VALVE (PAID FOR AS GATE VALVE AND BOX, 8 INCH, MODIFIED)  
1 EA - 8" PLUG (TEMPORARY)  
1 EA - 2" BLOW-OFF AND COPPER LINE TO SURFACE (TEMPORARY)  
CONNECTION TO EXISTING WATER MAIN SHALL BE MADE AFTER THE PROPOSED WATER MAIN HAS BEEN TESTED AND APPROVED FOR SERVICE

CONSTRUCTION QUANTITIES (THIS SHEET)		
QUANTITY	UNIT	WORK ITEM
4	Cyd	Subbase, CIP
175	Syd	Aggregate Base, 8 inch, Modified
63	Ton	HMA, 13A
15	Syd	Driveway, Nonreinf Conc, 6 inch
93	Syd	Driveway, Nonreinf Conc, 7 inch
89	Ft	Curb and Gutter, Conc, Det F4, Modified
225	Sft	Sidewalk, Conc, 4 inch
28	Sft	Sidewalk, Conc, 6 inch
350	Syd	Turf Establishment, Performance
1	Ea	Connect to Existing Water Main
1	Ea	Existing Valve with Valve Box Abandonment
200	Ft	Water Main, C909 PVC, 8 inch, TB Detail G, Modified
475	Ft	Water Main, C900 PVC, 8 inch, Bore
1	Ea	Water Main, 4 inch, Cut and Plug, Modified
1	Ea	Gate Valve and Box, 8 inch, Modified
1	Ea	Fire Hydrant and Valve Assembly
250	Ft	1" Copper Service Lead, Type "K", Modified
11	Ea	Curb Box, Stop, 1 inch Corporation Stop and Connection, Modified
2	Ea	Supply & Install Meter Pit, Complete
2	Ea	Water Meter Pit, Rem

**YOUNG STREET**  
WATER MAIN PLAN

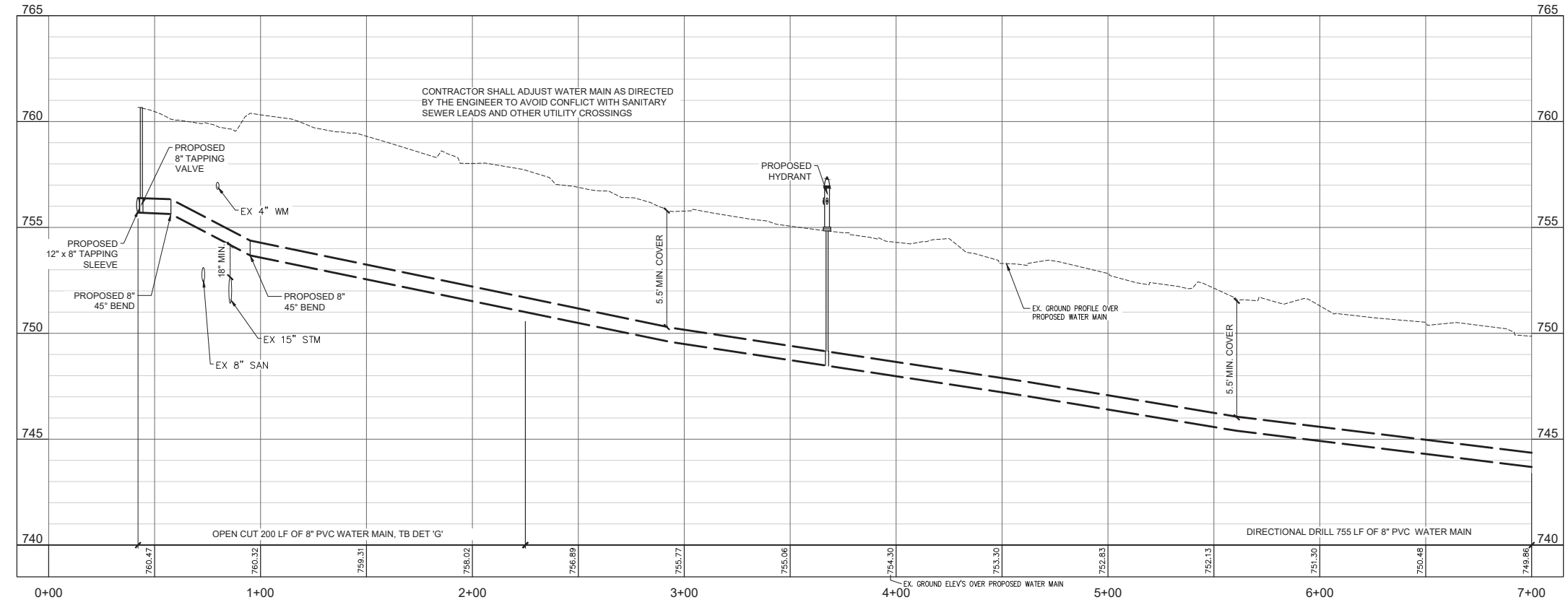

**CITY OF OWOSSO, MICHIGAN**  
**ENGINEERING DIVISION**  
**DEPT. OF PUBLIC SERVICE**

NO.	DATE	BY	REVISIONS	APPROVED BY
			1	
BENCH MARK DATA			DESCRIPTION	ELEV.

2024 WATER MAIN REPLACEMENT PROJECT - DWSRF 7497-01  
YOUNG STREET  
WATER MAIN PLAN AND PROFILE  
JANUARY, 2024  
PROJECT NO.

FIELD BOOK  
P.G.

YN4



NO.	DATE	BY	DESCRIPTION
1	1/15/24	CW	IFB PLANS
			REVISIONS
			CHECKED BY
			APPROVED BY

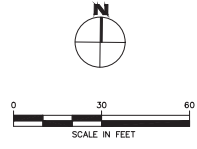

- LEGEND**
- WATER MAIN
  - WATER SERVICE LINE
  - ✕ GATE VALVE AND BOX, \_\_ INCH
  - REDUCER
  - ⊕ HYDRANT / VALVE
  - ⊙ CURB STOP
  - ⊙ METER PIT
  - ▨ Curb Ramp, Conc., \_\_ inch
  - ▨ Sidewalk, Conc., \_\_ inch
  - ▨ Aggregate Base, 8 inch, Modified and HMA, 13
  - ▨ Driveway, Nonrein Conc., \_\_ inch
  - ▨ Approach, Cl II, LM
  - ⊙ Bore Pit
  - ⊙ STANDARD SOIL EROSION KEY

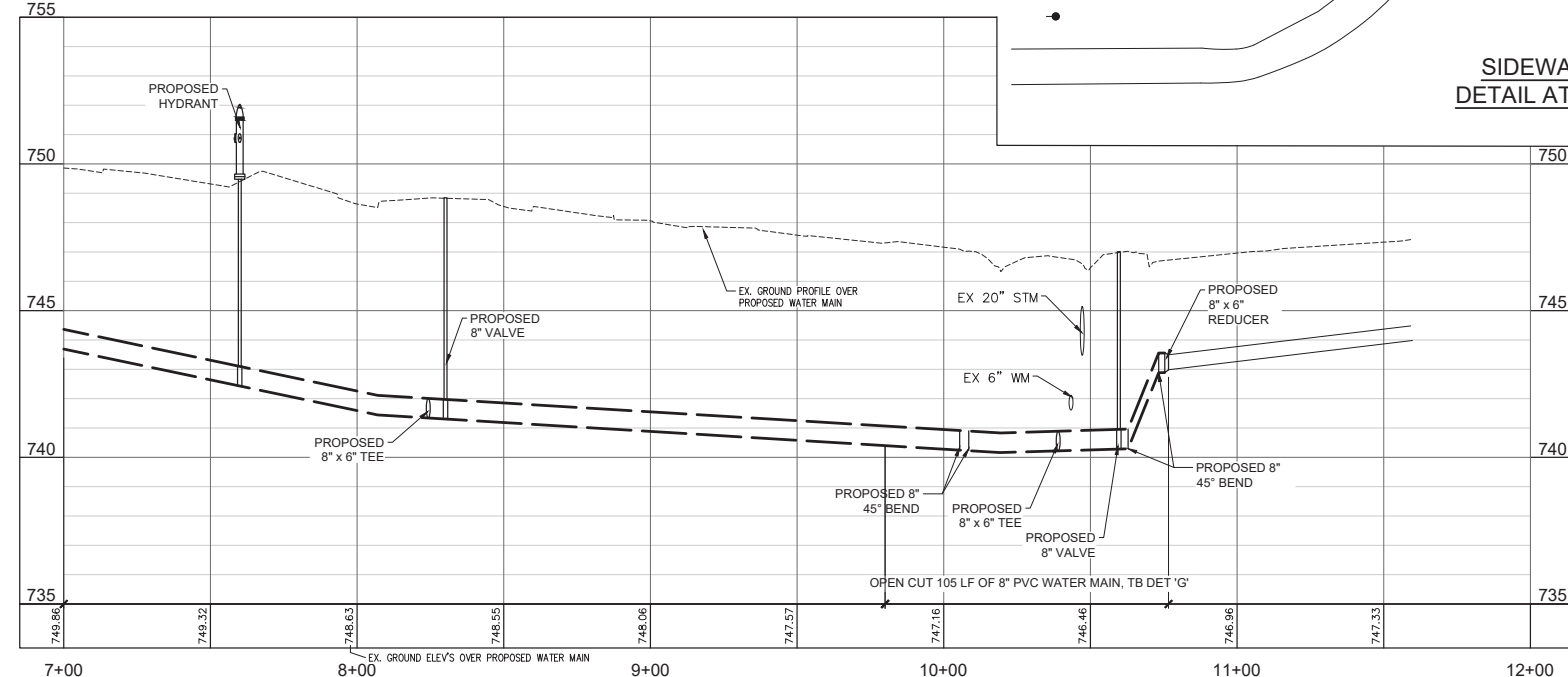
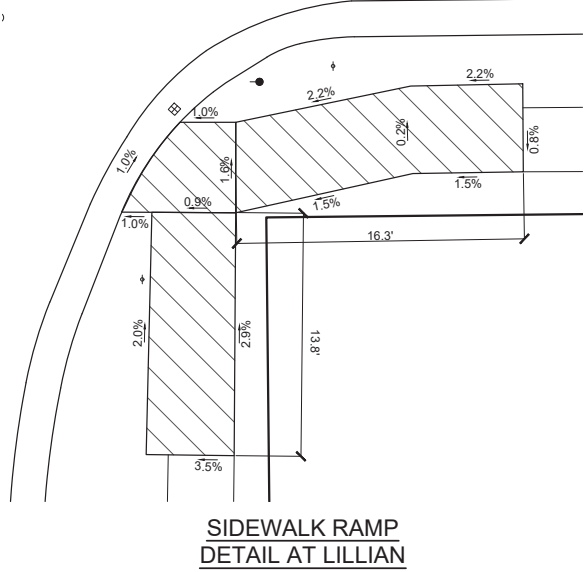
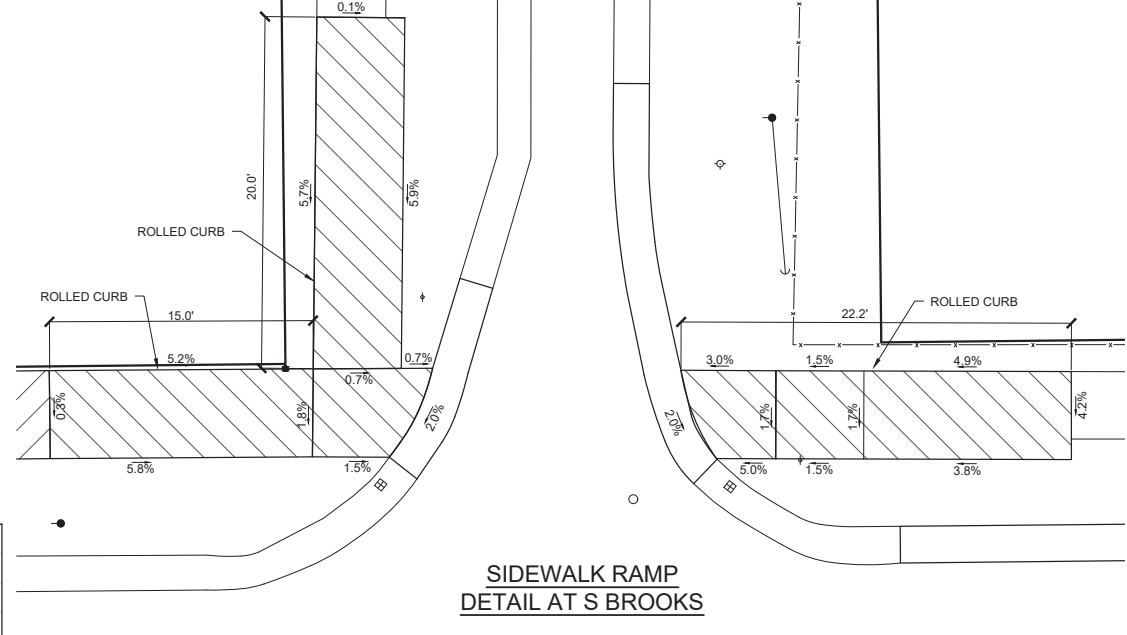
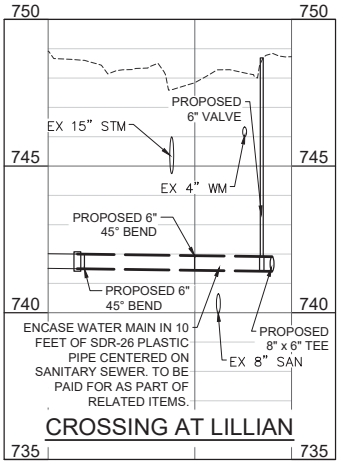
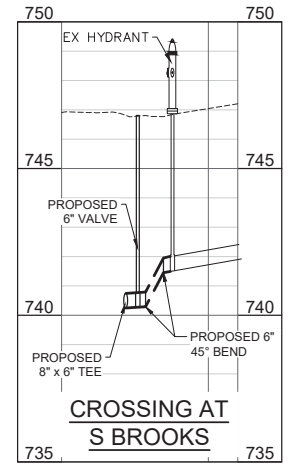
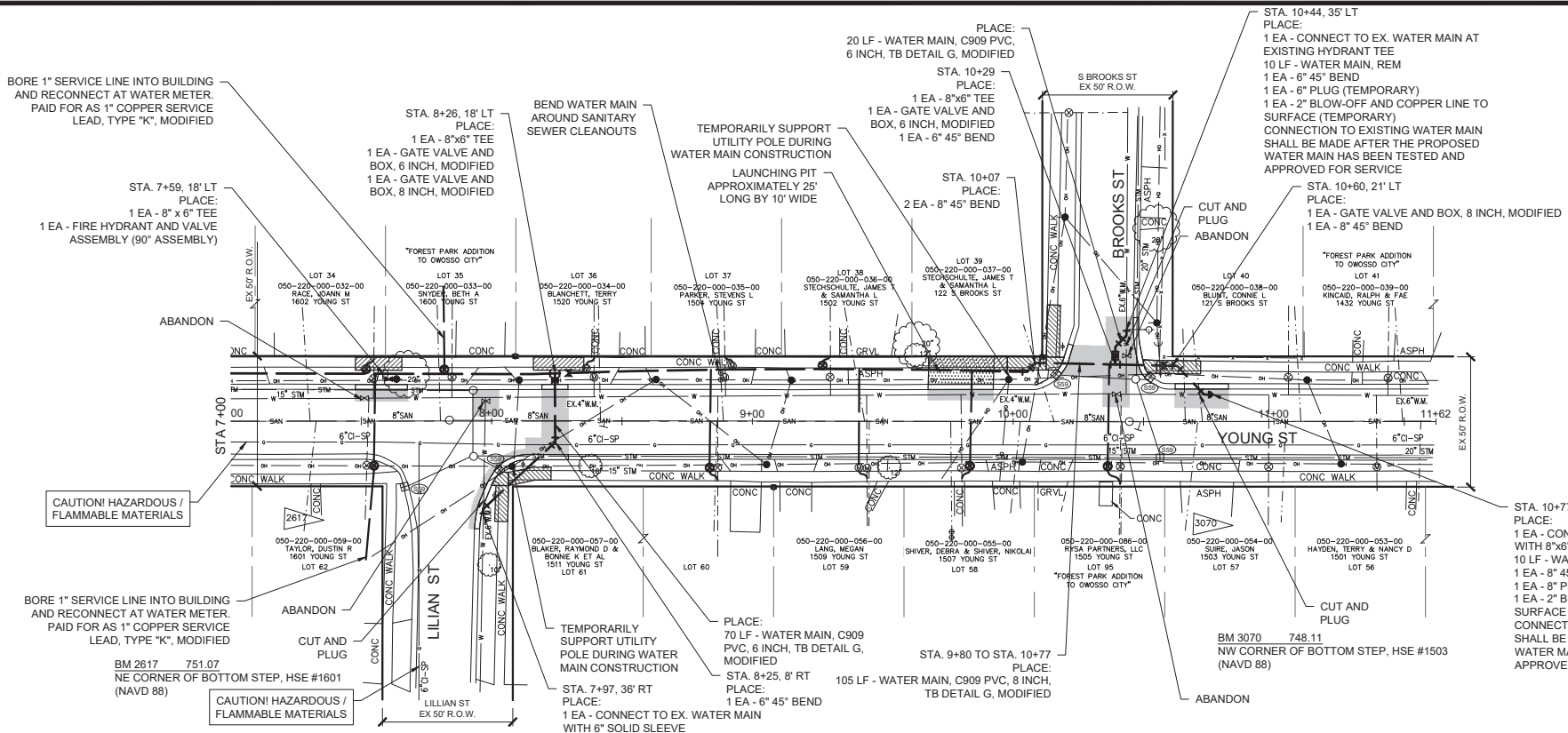

**CONSTRUCTION QUANTITIES (THIS SHEET)**

QUANTITY	UNIT	WORK ITEM
11	Cyd	Subbase, CIP
148	Syd	Aggregate Base, 8 inch, Modified
54	Ton	HMA, 13A
158	Ft	Curb and Gutter, Conc, Det F4, Modified
15	Ft	Detectable Warning Surface, Modified
21	Ft	Curb Ramp Opening, Conc
408	Sft	Curb Ramp, Conc, 4 inch
79	Sft	Curb Ramp, Conc, 7 inch
337	Sft	Sidewalk, Conc, 4 inch
350	Syd	Turf Establishment, Performance
3	Ea	Connect to Existing Water Main
30	Ft	Water Main, Rem
3	Ea	Existing Valve with Valve Box Abandonment
90	Ft	Water Main, C909 PVC, 6 inch, TB Detail G, Modified
105	Ft	Water Main, C909 PVC, 6 inch, TB Detail G, Modified
280	Ft	Water Main, C909 PVC, 6 inch, Bore
1	Ea	Water Main, 4 inch, Cut and Plug, Modified
2	Ea	Water Main, 6 inch, Cut and Plug, Modified
2	Ea	Gate Valve and Box, 6 inch, Modified
2	Ea	Gate Valve and Box, 8 inch, Modified
1	Ea	Fire Hydrant and Valve Assembly
340	Ft	1" Copper Service Lead, Type "K", Modified
10	Ea	Curb Box, Stop, 1 inch Corporation Stop and Connection, Modified
3	Ea	Supply & Install Meter Pit, Complete
3	Ea	Water Meter Pit, Rem